

# 4.0 & 4.6 litre V8 ENGINE



## Overhaul Manual

---

4.0 & 4.6 Liter V8 motor  
revisiehandboek

Moteur de 4.0 & 4.6L V8  
Manuel de révision

4.0 & 4.6L V8 motor  
Überholungsanleitung

Motore 4.0 & 4.6 Litri V8  
Manuale di revisione

Motor 4.0 & 4.6 Litro V8  
Manual de revisión

Motor da 4.0 & 4.6L V8  
Manual de revisão

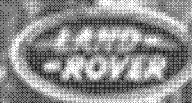

# 4.0 & 4.6 LITRE V8 ENGINE

## OVERHAUL MANUAL

---

These engines having Serial No. Prefix  
42D, 46D, 47D, 48D, 49D, 50D or 51D are  
fitted to the following models:

**New Range Rover**

**Discovery - North American  
Specification - 1996 MY Onwards**

**Defender - North American Specification  
- 1997 MY Onwards**

**Defender V8i Automatic**

**Publication Part No. LRL 0004ENG - 3rd Edition  
Published by Rover Technical Communication**

© 1998 Rover Group Limited



**CONTENTS**

Page



**INFORMATION**

INTRODUCTION ..... 1  
REPAIRS AND REPLACEMENTS ..... 2  
SPECIFICATION ..... 2



---

## INTRODUCTION

---

### How to use this Manual

To assist in the use of this Manual the section title is given at the top and the relevant sub-section is given at the bottom of each page.

This manual contains procedures for overhaul of the V8 engine on the bench with the gearbox, clutch, inlet manifold, exhaust manifolds, coolant pump, starter motor, alternator, and all other ancillary equipment removed. For information regarding General Information, Adjustments, removal of oil seals, engine units and ancillary equipment, consult the Repair Manual.

This manual is divided into 3 sections:

- Data, Torque & Tools
- Description and Operation and
- Overhaul

To assist filing of revised information each sub-section is numbered from page 1.

Individual items are to be overhauled in the sequence in which they appear in this manual. Items numbers in the illustrations are referred to in the text.

Overhaul operations include reference to Service tool numbers and the associated illustration depicts the tool. Where usage is not obvious the tool is shown in use. Land Rover tool numbers are quoted, for the equivalent Rover Cars tool number refer to the Service Tool section. Operations also include reference to wear limits, relevant data, and specialist information and useful assembly details.

**WARNINGS, CAUTIONS** and **NOTES** have the following meanings:



**WARNING:** Procedures which must be followed precisely to avoid the possibility of injury.



**CAUTION:** Calls attention to procedures which must be followed to avoid damage to components.



**NOTE:** Gives helpful information.

### References

With the engine and gearbox assembly removed, the crankshaft pulley end of the engine is referred to as the front. References to RH and LH banks of cylinders are taken viewing from the flywheel end of the engine.

Operations covered in this Manual do not include reference to testing the vehicle after repair. It is essential that work is inspected and tested after completion and if necessary a road test of the vehicle is carried out particularly where safety related items are concerned.

### Engine serial number

The engine serial number and compression ratio will be found stamped on a cast pad on the cylinder block between numbers 3 and 5 cylinders. The compression ratio is above the serial number.

### Dimensions

The dimensions quoted are to design engineering specification with Service Limits where applicable.

# INTRODUCTION

---

---

## REPAIRS AND REPLACEMENTS

---

When replacement parts are required it is essential that only Land Rover recommended parts are used.

Attention is particularly drawn to the following points concerning repairs and the fitting of replacement parts and accessories.

Torque wrench setting figures given in this Manual must be used. Locking devices, where specified, must be fitted. If the efficiency of a locking device is impaired during removal it must be renewed.

The terms of the vehicle warranty may be invalidated by the fitting of parts other than Land Rover recommended parts. All Land Rover recommended parts have the full backing of the vehicle warranty.

Land Rover dealers are obliged to supply only Land Rover recommended parts.

---

## SPECIFICATION

---

Land Rover are constantly seeking to improve the specification, design and production of their vehicles and alterations take place accordingly. While every effort has been made to ensure the accuracy of this Manual, it should not be regarded as an infallible guide to current specifications of any particular vehicle.

This Manual does not constitute an offer for sale of any particular component or vehicle. Land Rover dealers are not agents of the Company and have no authority to bind the manufacturer by any expressed or implied undertaking or representation.

**CONTENTS**

Page



**GENERAL DATA**

DATA ..... 1

**TORQUE WRENCH SETTINGS**

ENGINE ..... 1

GENERAL ..... 2

**SERVICE TOOLS**

SERVICE TOOLS ..... 1



**DATA**

**Firing order** ..... 1, 8, 4, 3, 6, 5, 7, 2  
 Cylinders 1, 3, 5, 7 - LH side of engine  
 Cylinders 2, 4, 6, 8 - RH side of engine

**Cylinder heads**

Maximum warp ..... 0.05 mm                      0.002 in  
 Reface limit ..... 0.50 mm                      0.02 in

**Valve springs**

Free length ..... 48.30 mm                      1.90 in  
 Fitted length ..... 40.40 mm                      1.60 in  
 Load - valve open ..... 736 ± 10 N                      165 ± 2 lbf  
 Load - valve closed ..... 339 ± 10 N                      76 ± 2 lbf

**Valves**

Valve stem diameter:  
 Inlet ..... 8.664 to 8.679 mm                      0.341 to 0.342 in  
 Exhaust ..... 8.651 to 8.666 mm                      0.340 to 0.341 in  
 Valve head diameter:  
 Inlet ..... 39.75 to 40.00 mm                      1.5 to 1.6 in  
 Exhaust ..... 34.226 to 34.480 mm                      1.3 to 1.4 in  
 Valve installed height - maximum ..... 47.63 mm                      1.9 in  
 Valve stem to guide clearance:  
 Inlet ..... 0.025 to 0.066 mm                      0.001 to 0.002 in  
 Exhaust ..... 0.038 to 0.078 mm                      0.0015 to 0.003 in

**Valve guides**

Valve guide installed height ..... 15.0 mm                      0.590 in  
 Inside diameter after reaming ..... 8.7 mm                      0.34 in

**Valve seats**

Valve seat angle ..... 46° to 46° 25'  
 Valve seat width:  
 Inlet ..... 36.83 mm                      1.45 in  
 Exhaust ..... 31.50 mm                      1.24 in  
 Valve seating width:  
 Inlet ..... 0.89 to 1.4 mm                      0.035 to 0.055 in  
 Exhaust ..... 1.32 to 1.83 mm                      0.052 to 0.072 in  
 Valve seating face angle ..... 45°

**Oil pump**

Inner to outer rotor clearance - maximum ..... 0.25 mm                      0.01 in  
 Rotors to cover plate clearance - maximum ..... 0.1 mm                      0.004 in  
 Drive gear wear step depth - maximum ..... 0.15 mm                      0.006 in

**Oil pressure relief valve**

Spring free length ..... 60.0 mm                      2.4 in

**Camshaft**

End-float ..... 0.05 to 0.35 mm                      0.002 to 0.014 in  
 Maximum run-out ..... 0.05 mm                      0.002 in

## INFORMATION

---

### Piston rings

Ring to groove clearance:

1st compression	0.05 to 0.10 mm	0.002 to 0.004 in
2nd compression	0.05 to 0.10 mm	0.002 to 0.004 in
Ring fitted gap:		
1st compression	0.3 to 0.5 mm	0.01 to 0.02 in
2nd compression	0.40 to 0.65 mm	0.016 to 0.03 in
Oil control rails	0.38 to 1.40 mm	0.014 to 0.05 in
Oil control ring width	3.00 mm	0.12 in - maximum

### Pistons

Piston diameter:

Production - Grade A	93.970 to 93.985 mm	3.700 to 3.7002 in
Production - Grade B*	93.986 to 94.0 mm	3.7003 to 3.701 in
Clearance in bore	0.02 to 0.045 mm	0.001 to 0.002 in

### Gudgeon pins

Length	60.00 to 60.50 mm	2.35 to 2.4 in
Diameter	23.995 to 24.000 mm	0.94 to 0.95 in
Clearance in piston	0.006 to 0.015 mm	0.0002 to 0.0006 in

### Connecting rods

Length between centres:

4.0 litre	155.12 to 155.22 mm	6.10 to 6.11 in
4.6 litre	149.68 to 149.78 mm	5.89 to 5.91 in

### Cylinder bore

Cylinder bore:

Grade A piston fitted	94.00 to 94.015 mm	3.700 to 3.701 in
Grade B piston fitted	94.016 to 94.030 mm	3.7014 to 3.702 in
Cylinder bore maximum ovality	0.013 mm	0.0005 in

### Crankshaft

Main journal diameter	63.487 to 63.500 mm	2.499 to 2.52 in
Minimum regrind diameter	62.979 to 62.992 mm	2.509 to 2.510 in
Maximum out of round	0.040 mm	0.002 in
Big-end journal diameter	55.500 to 55.513 mm	2.20 to 2.22 in
Minimum regrind diameter	54.992 to 55.005 mm	2.16 to 2.165 in
Maximum out of round	0.040 mm	0.002 in
End-float	0.10 to 0.20 mm	0.004 to 0.008 in
Maximum run-out	0.08 mm	0.003 in

### Main bearings

Main bearing diametrical clearance	0.010 to 0.048 mm	0.0004 to 0.002 in
Oversizes	0.254, 0.508 mm	0.01, 0.02 in





**Big-end bearings**

Big-end bearing diametrical clearance . . . . .	0.015 to 0.055 mm	0.0006 to 0.0021 in
Oversizes . . . . .	0.254, 0.508 mm	0.01, 0.02 in
End-float on journal . . . . .	0.15 to 0.36 mm	0.006 to 0.01 in

**Flywheel**

Flywheel minimum thickness . . . . .	40.45 mm	1.6 in
--------------------------------------	----------	--------

**Drive plate**

Drive plate setting height:

Up to engine no. 42D00593A - 4.0 litre . . . . .	21.25 to 21.37 mm	0.83 to 0.84 in
Up to engine no. 46D00450A - 4.6 litre . . . . .	7.69 to 7.81 mm	0.30 to 0.31 in

\* Grade B piston supplied as service replacement



**ENGINE**

Crankshaft pulley bolt	270 Nm	200 lbf.ft
Camshaft gear bolt	50 Nm	37 lbf.ft
Camshaft thrust plate bolts	25 Nm	18 lbf.ft
Rocker cover bolts: +		
Stage 1	4 Nm	3 lbf.ft
Stage 2	8 Nm	6 lbf.ft
Stage 3 - re-torque to:	8 Nm	6 lbf.ft
Rocker shaft to cylinder head bolts	38 Nm	28 lbf.ft
Cylinder head bolts: +*		
Stage 1	20 Nm	15 lbf.ft
Stage 2	Then 90 degrees	
Stage 3	Further 90 degrees	
Lifting eye to cylinder head bolts	40 Nm	30 lbf.ft
Connecting rod bolts:		
Stage 1	20 Nm	15 lbf.ft
Stage 2	Further 80 degrees	
Main bearing cap bolts - Nos. 1 to 8: +		
Stage 1 - initial torque	13.5 Nm	10 lbf.ft
Stage 2 - final torque	72 Nm	53 lbf.ft
Rear main bearing cap bolts - Nos. 9 and 10: +		
Stage 1 - initial torque	13.5 Nm	10 lbf.ft
Stage 2 - final torque	92 Nm	68 lbf.ft
Main bearing cap side bolts - Nos. 11 to 20: +		
Stage 1 - initial torque	13.5 Nm	10 lbf.ft
Stage 2 - final torque	45 Nm	33 lbf.ft
Flywheel bolts	80 Nm	59 lbf.ft
Drive plate assembly bolts	45 Nm	33 lbf.ft
Drive plate hub aligner to crankshaft socket head cap screws	85 Nm	63 lbf.ft
Oil sump drain plug	45 Nm	33 lbf.ft
Oil sump nuts and bolts +	23 Nm	17 lbf.ft
Oil pump cover plate screws **	4 Nm	3 lbf.ft
Oil pump cover plate bolt **	8 Nm	6 lbf.ft
Spark plugs	20 Nm	15 lbf.ft
Timing cover/coolant pump to cylinder block bolts		
+	22 Nm	16 lbf.ft
Oil pick-up pipe to oil pump bolts	8 Nm	6 lbf.ft
Oil pick-up pipe nut	24 Nm	18 lbf.ft
Knock sensors to cylinder block	16 Nm	12 lbf.ft
Camshaft sensor to timing cover bolt	8 Nm	6 lbf.ft
Crankshaft position sensor bolts	6 Nm	4 lbf.ft
Oil cooler connections	15 Nm	11 lbf.ft

+ Tighten in sequence

\* Lightly oil threads prior to assembly.

\*\* Coat threads with Loctite 222 prior to assembly.

# INFORMATION

---

---

## GENERAL

---

For bolts and nuts not otherwise specified

M5	4 Nm	3 lbf.ft
M6	6 Nm	4 lbf.ft
M8	18 Nm	13 lbf.ft
M10	35 Nm	26 lbf.ft
M12	65 Nm	48 lbf.ft
M14	80 Nm	59 lbf.ft
M16	130 Nm	96 lbf.ft
$\frac{1}{4}$ UNC/UNF	9 Nm	7 lbf.ft
$\frac{5}{16}$ UNC and UNF	25 Nm	18 lbf.ft
$\frac{3}{8}$ UNC and UNF	40 Nm	30 lbf.ft
$\frac{7}{16}$ UNC and UNF	75 Nm	55 lbf.ft
$\frac{1}{2}$ UNC and UNF	90 Nm	66 lbf.ft
$\frac{5}{8}$ UNC and UNF	135 Nm	100 lbf.ft



---

**SERVICE TOOLS**

---

Land Rover Number	Rover Number	Description
LRT-12-013	18G1150	Remover/replacer - gudgeon pin
LRT-12-126/1	-	Adapter - remover/replacer - gudgeon pin
LRT-12-126/2	-	Adapter - remover/replacer - gudgeon pin
LRT-12-126/3	-	Parallel sleeve - gudgeon pin
LRT-12-034	18G1519A	Valve spring compressor
LRT-12-037	RO274401	Drift - remover - valve guide
LRT-12-038	RO600959	Drift - replacer - valve guide
LRT-12-055	-	Distance piece - valve guide
LRT-12-089	-	Replacer - timing cover oil seal
LRT-12-090	-	Retainer - oil pump gears
LRT-12-091	-	Replacer - crankshaft rear oil seal
LRT-12-095	-	Protection sleeve - crankshaft rear oil seal
LRT-12-501	MS76B	Basic handle set - valve seat cutters
LRT-12-503	MS150-8.5	Adjustable valve seat pilot
LRT-12-515	RO605774A	Distance piece - valve guide
LRT-12-517	-	Adjustable valve seat cutter

Service tools must be obtained direct from the manufacturers:

V.L. Churchill,  
P.O. Box No 3,  
London Road,  
Daventry,  
Northants, NN11 4NF  
England.

## CONTENTS

Page

### DESCRIPTION AND OPERATION

CYLINDER BLOCK COMPONENTS .....	3
CYLINDER HEAD COMPONENTS .....	5
OPERATION .....	6

### OVERHAUL

ROCKER SHAFTS .....	1
Rocker shafts - remove .....	1
Rocker shafts - dismantling .....	2
Inspecting components .....	2
Rocker shafts - assembling .....	3
Rocker shafts - refit .....	3
CYLINDER HEAD .....	4
Cylinder head - remove .....	4
Valves and springs - remove .....	5
Cylinder head - inspection .....	5
Valves, valve springs and guides - inspection .....	6
Valve guides - renew .....	8
Valve seat inserts - inspection .....	9
Valve seat inserts - renew .....	10
Valve seats and seat inserts - refacing .....	10
Valves - lapping-in .....	12
Valves and springs - refit .....	12
Cylinder head - refit .....	13
TIMING CHAIN AND GEARS .....	14
Sump - remove .....	14
Timing cover - remove .....	14
Timing gears - remove .....	15
Timing chain and gears - inspection .....	16
Timing gears - refit .....	16
Timing cover - refit .....	17
Sump - refit .....	19
OIL PUMP AND OIL PRESSURE RELIEF VALVE .....	20
Oil pump - remove .....	20
Oil pressure relief valve - remove .....	21
Oil pump - inspection .....	22
Oil pressure relief valve - inspection .....	23
Oil pump - refit .....	23
Oil pressure relief valve - refit .....	24
CAMSHAFT AND TAPPETS .....	24
Camshaft end-float - check .....	24
Camshaft and tappets - remove .....	25
Camshaft and tappets - inspection .....	26
Camshaft and tappets - refit .....	26
PISTONS, CONNECTING RODS, PISTON RINGS AND CYLINDER BORES ...	27
Pistons and connecting rods - remove .....	27
Piston rings - remove .....	27
Piston rings - inspection .....	28
Pistons - remove .....	28
Pistons - inspection .....	29
Gudgeon pins - inspection .....	29
Cylinder liner bore - inspection .....	30



# ENGINE

---

## CONTENTS

	Page
Pistons - refit .....	31
Piston to cylinder bore clearance - checking .....	32
Pistons and connecting rods - refit .....	32
FLYWHEEL AND STARTER RING GEAR .....	33
Flywheel - remove .....	33
Flywheel and starter ring gear - inspection .....	34
Starter ring gear - renew .....	34
Flywheel - refit .....	35
DRIVE PLATE AND RING GEAR ASSEMBLY .....	36
Drive plate and ring gear assembly - remove - Up to engine nos. 42D00593A and 46D00450A .....	36
Drive plate and ring gear assembly - remove - From engine nos. 42D00594A and 46D00451A and all engines having serial no. prefixes from 47D to 51D .....	36
Drive plate and ring gear - inspection .....	37
Drive plate and ring gear assembly - refit - Up to engine nos. 42D00593A and 46D00450A .....	37
Drive plate and ring gear assembly - refit - From engine nos. 42D00594A and 46D00451A and all engines having serial no. prefixes from 47D to 51D .....	38
CRANKSHAFT, MAIN AND BIG-END BEARINGS .....	39
Big-end bearings - remove .....	39
Big-end bearings - refit .....	40
Crankshaft - remove .....	41
Knock sensor - remove .....	42
Crankshaft position sensor - remove .....	42
Crankshaft - inspection .....	43
Crankshaft spigot bearing - renew .....	44
Crankshaft - refit .....	45
Crankshaft end - float - check .....	47
Knock sensor - refit .....	47
Crankshaft position sensor - refit .....	48

---



This page is intentionally left blank

# ENGINE

---

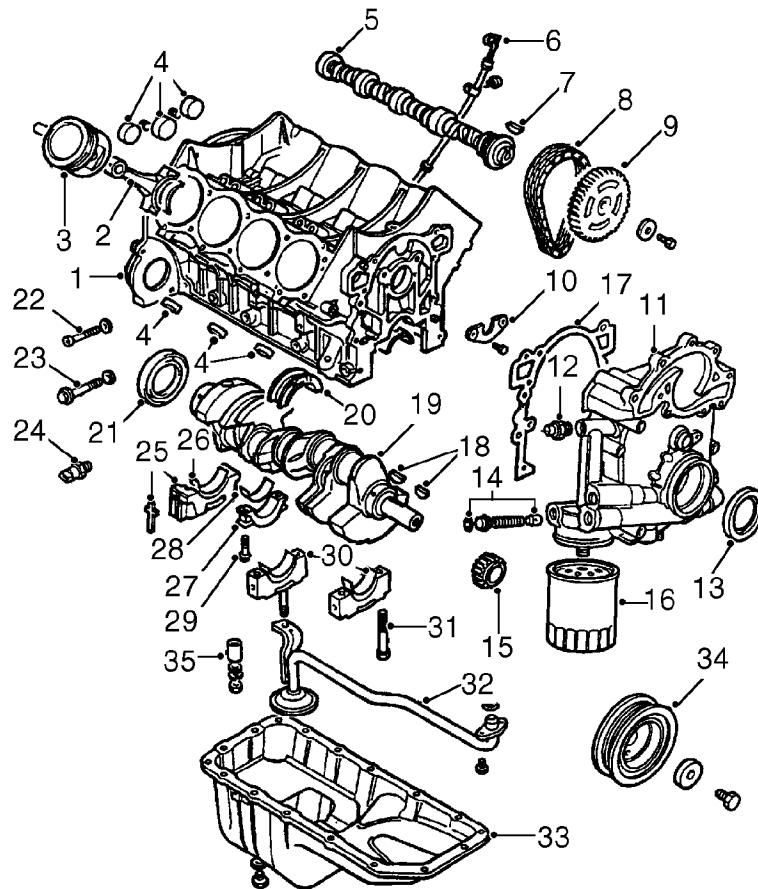

12M1374B





---

**CYLINDER BLOCK COMPONENTS**

---

1. Cylinder block
2. Connecting rod
3. Piston and gudgeon pin
4. Core plugs
5. Camshaft
6. Dipstick
7. Camshaft Woodruff key
8. Timing chain
9. Camshaft sprocket
10. Thrust plate
11. Timing cover and oil pump assembly \*
12. Oil pressure switch
13. Timing cover oil seal
14. Oil pressure relief valve assembly
15. Crankshaft sprocket
16. Oil filter
17. Timing cover gasket
18. Woodruff keys
19. Crankshaft
20. Centre main bearing shell - upper
21. Crankshaft rear oil seal
22. Main bearing socket head cap bolt
23. Main bearing hexagonal head bolt
24. Crankshaft knock sensor
25. Rear main bearing cap and side seals
26. Rear main bearing shell
27. Big end bearing cap
28. Big end bearing shell
29. Big end bearing bolt
30. Centre and front main bearing caps
31. Main bearing cap bolt
32. Oil pick-up pipe
33. Sump
34. Crankshaft pulley
35. Oil pick-up pipe spacer, washers and nut

\* New Range Rover timing cover illustrated

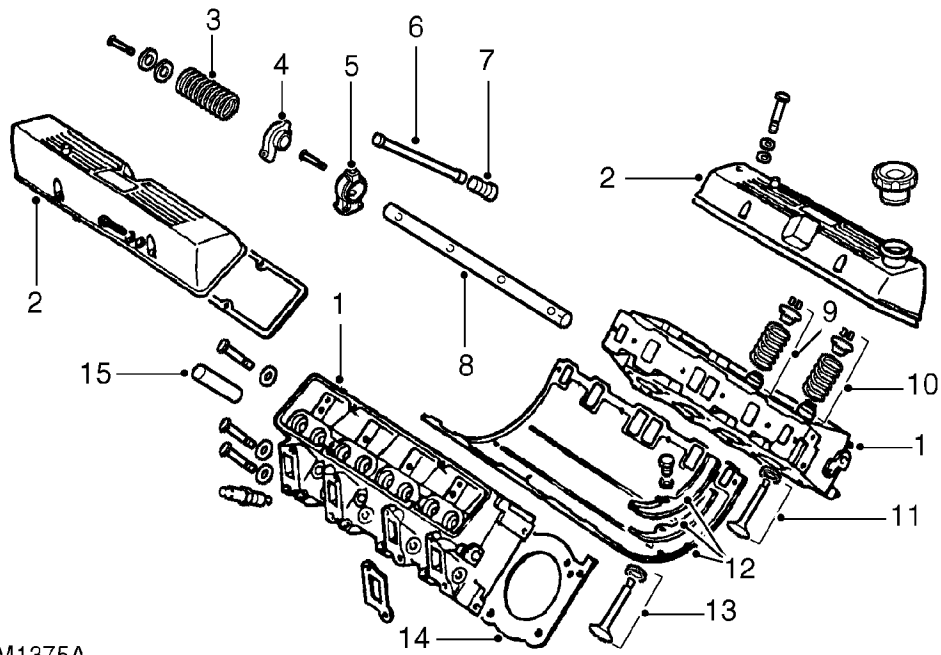

12M1375A



---

**CYLINDER HEAD COMPONENTS**

---

1. Cylinder head
2. Rocker cover
3. Rocker shaft spring
4. Rocker arm
5. Rocker shaft bracket
6. Pushrod
7. Tappet
8. Rocker shaft
9. Inlet valve seal, spring, cap and collets
10. Exhaust valve seal, spring, cap and collets
11. Exhaust valve and seat
12. Inlet manifold gasket and seals
13. Inlet valve and seat
14. Cylinder head gasket
15. Valve guide

## ENGINE

---

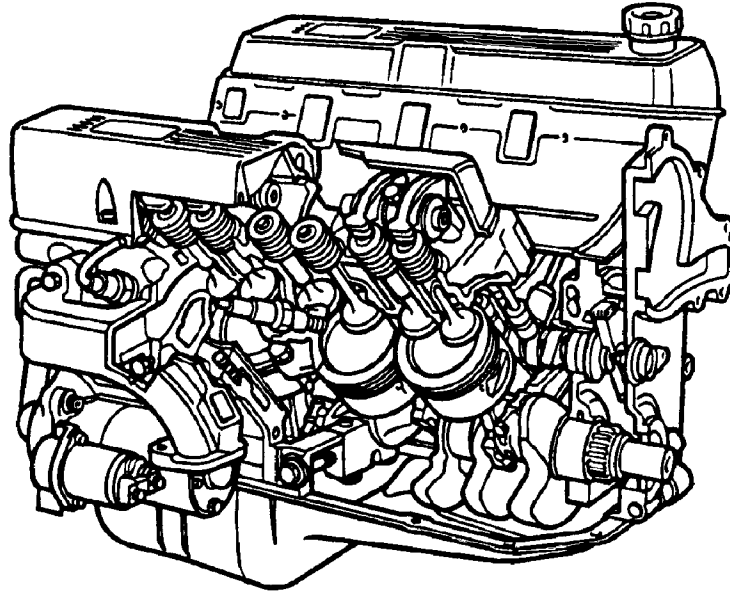

12M1384

---

### OPERATION

---

The V8 engine is an eight cylinder, water cooled unit comprising cast aluminium cylinder block and cylinder heads.

The cast iron cylinder liners are shrink fitted and located on stops in the cylinder block. The banks of cylinders are at 90° to each other. The crankshaft is carried in five main bearings, end-float being controlled by the thrust faces of the upper centre main bearing shell.

The centrally located camshaft is driven by the crankshaft via a chain. The valves are operated by rockers, pushrods and hydraulic tappets. Exhaust valves used on later engines are of the 'carbon break' type which incorporate a machined undercut at the combustion chamber end of the valve. The design prevents carbon build-up on the valve stem which could lead to valves sticking. These valves are interchangeable with valves fitted to early engines.

Each of the aluminium alloy pistons has two compression rings and an oil control ring. The pistons are secured to the connecting rods by semi-floating gudgeon pins. The gudgeon pin is offset 0.5 mm (0.02 in), identified by an arrow mark on the piston crown, which must always point to the front of the engine. Plain, big-end bearing shells are fitted to each connecting rod.

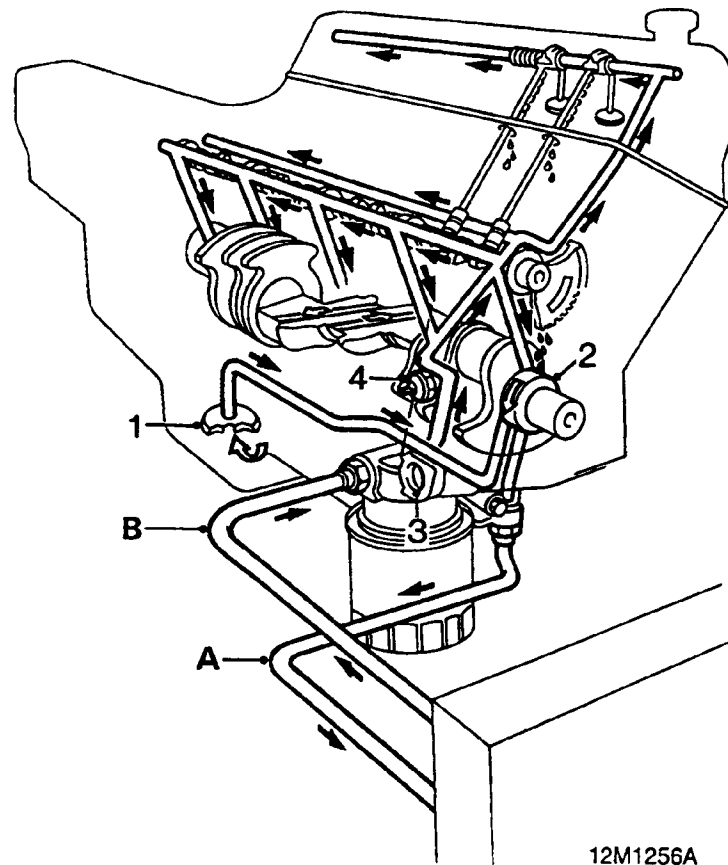

12M1256A

- |  |  |
|--|--|
| <ul style="list-style-type: none"> <li>1. Oil strainer</li> <li>2. Oil pump</li> <li>3. Pressure relief valve</li> </ul> | <ul style="list-style-type: none"> <li>4. Oil pressure switch</li> <li>A Oil to cooler</li> <li>B Oil from cooler</li> </ul> |
|--|--|

### Lubrication

The full flow lubrication system uses a gear type oil pump driven from the crankshaft. The assembly is integral with the timing cover which also carries the full flow oil filter, oil pressure switch and pressure relief valve.

Oil is drawn from the pressed steel sump through a strainer and into the oil pump, excess pressure being relieved by the pressure relief valve. The oil pressure warning light switch is screwed into the timing cover and registers the oil pressure in the main oil gallery on the outflow side of the filter.

Pressurised oil passes through an oil cooler mounted in front of the radiator to the full flow oil filter. The oil then passes through internal drillings to the crankshaft where it is directed to each main bearing and to the big end bearings via numbers 1, 3 and 5 main bearings.

An internal drilling in the cylinder block directs oil to the camshaft where it passes through further internal drillings to the hydraulic tappets, camshaft journals and rocker shaft. Lubrication to the thrust side of the cylinders is either by oil grooves machined in each connecting rod big end joint face or by splash.

# ENGINE

---

## Hydraulic tappets

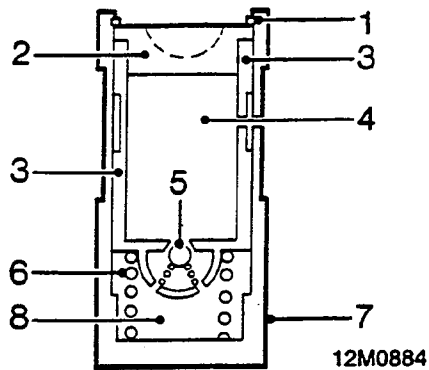

1. Clip
2. Pushrod seat
3. Inner sleeve
4. Upper chamber
5. Non-return ball valve
6. Spring
7. Outer sleeve
8. Lower chamber

The purpose of the hydraulic tappet is to provide maintenance free and quiet operation of valves. It achieves this by utilising engine oil pressure to eliminate the mechanical clearance between the rockers and the valve stems.

During normal operation, engine oil pressure, present in the upper chamber, passes through the non-return ball valve and into the lower chamber.

When the cam begins to lift the outer sleeve, the resistance of the valve spring, felt through the push rod and seat, causes the tappet inner sleeve to move downwards inside the outer sleeve. This downward movement of the inner sleeve closes the ball valve and increases the pressure in the lower chamber sufficiently to ensure that the push rod opens the valve fully.

As the tappet moves off the peak of the cam, the ball valve opens to equalise the pressure in both chambers which ensures the valve closes when the tappet is on the back of the cam.



**ROCKER SHAFTS**

**Rocker shafts - remove**

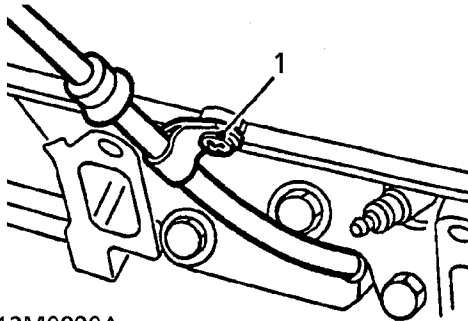

12M0890A

1. *LH rocker shaft only:* Remove screw securing dipstick tube to rocker cover.

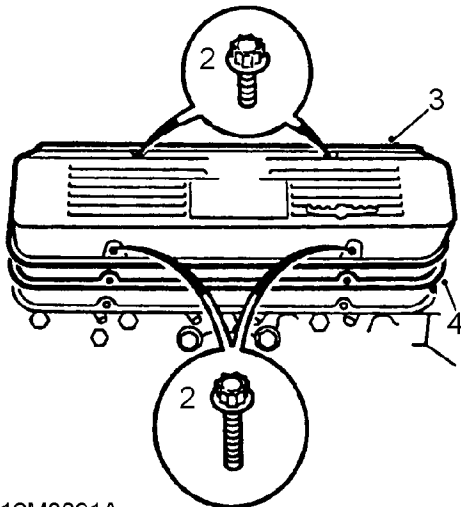

12M0891A

2. Remove 4 bolts securing rocker cover to cylinder head.



**NOTE:** Mark position of 2 longer bolts.

3. Remove rocker cover.
4. Remove and discard gasket from rocker cover.

5. Mark each rocker shaft in relation to original cylinder head.



**CAUTION:** Incorrect fitment of rocker shafts will lead to an oil feed restriction.

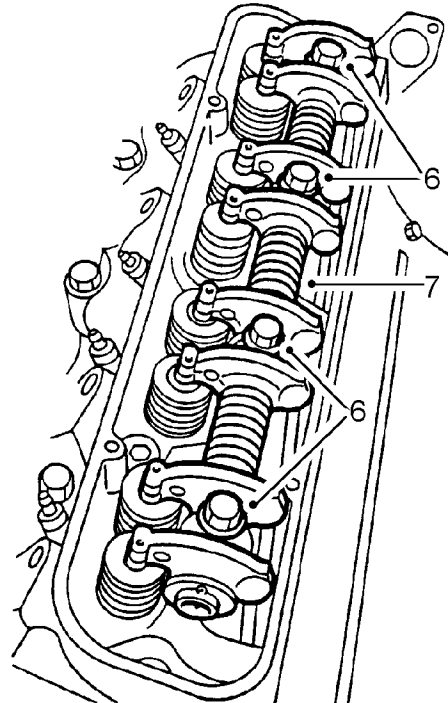

12M0892

6. Progressively slacken and remove 4 bolts securing rocker shaft assembly to cylinder head.
7. Remove rocker shaft assembly.
8. Remove pushrods and store in fitted order.

# ENGINE

---

## Rocker shafts - dismantling

---

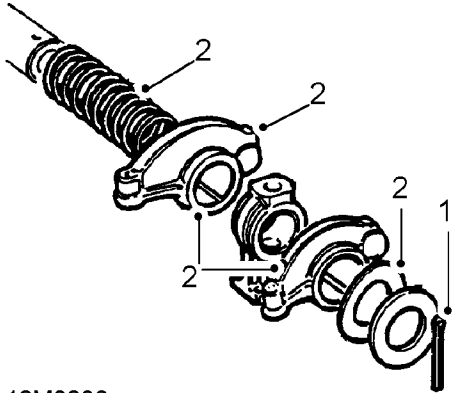

12M0886

1. Remove and discard split pin from one end of rocker shaft.
2. Remove plain washer, wave washer, rocker arms, brackets and springs.

## Inspecting components

---

1. Thoroughly clean components.
2. Inspect each component for wear, in particular rocker arms and shafts. Discard weak or broken springs.
3. Inspect pushrod seats in rocker arms.
4. Check pushrods for straightness and inspect ball ends for damage, replace as necessary.





### Rocker shafts - assembling

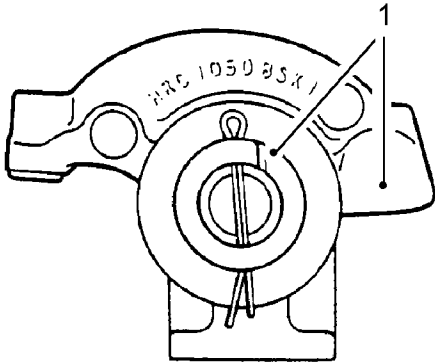

12M0887

1. Assemble rocker shafts with identification groove at one o'clock position with push rod end of rocker arm to the right.



**CAUTION:** Incorrect assembly of rocker shafts will lead to an oil feed restriction.

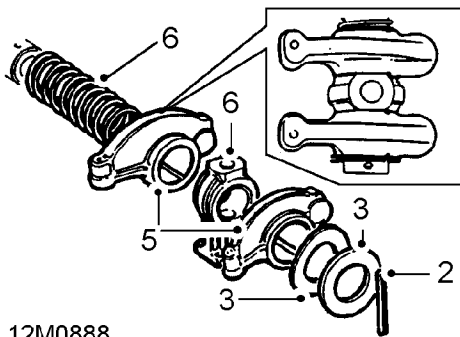

12M0888

2. Fit new split pin to one end of rocker shaft.
3. Fit plain washer and wave washer.
4. Lubricate rocker arm bushes with engine oil.
5. Fit rocker arms with offsets as illustrated.
6. Assemble rocker arms, brackets and springs to rocker shaft.
7. Compress springs, fit wave washer, plain washer and secure with new split pin.

### Rocker shafts - refit

1. Lubricate pushrods with engine oil.
2. Fit pushrods in removed order.

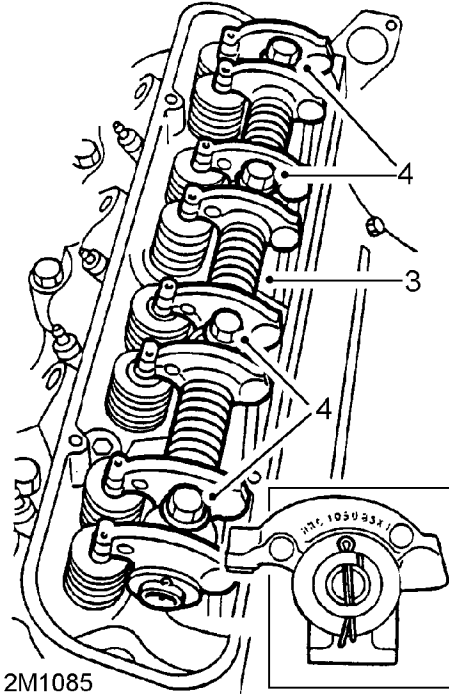

12M1085

3. Fit each rocker shaft assembly, ensuring identification groove is uppermost and towards front of engine on RH side and towards rear of engine on LH side.



**CAUTION:** Incorrect fitment of rocker shafts will lead to an oil feed restriction.

4. Fit bolts and starting at centre brackets, tighten to 38 Nm (28 lbf.ft).

5. Clean gasket surface in rocker cover.



**NOTE:** Gaskets fitted to early engines were manufactured from cork whilst those fitted to later engines are manufactured from rubber. The later type gaskets should be fitted as replacements to all engines. Cork gaskets were retained by an adhesive whereas rubber gaskets do not need an adhesive. If cork gaskets were originally fitted, remove all traces of adhesive using Bostik Cleaner 6001 or equivalent.

6. Fit new gasket, dry to rocker cover.
7. Fit rocker cover to cylinder head, fit bolts and tighten in diagonal sequence to:
  - Stage 1 - 4 Nm (3 lbf.ft)
  - Stage 2 - 8 Nm (6 lbf.ft)
  - Stage 3 - Re-torque to 8 Nm (6 lbf.ft)



**CAUTION:** The 2 short bolts must be fitted on side of cover nearest centre of engine.

8. *LH rocker shaft only:* Align dipstick tube to rocker cover, fit and tighten screw.

## CYLINDER HEAD

### Cylinder head - remove

1. Remove rocker shaft assembly.
2. Mark heads LH and RH for reassembly.

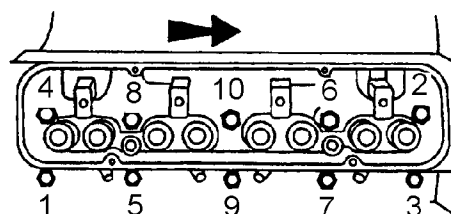

12M1249A



**NOTE:** RH cylinder head illustrated.

3. Using sequence shown, remove and discard 10 bolts securing cylinder head to cylinder block.
4. Release cylinder head from 2 dowels and remove cylinder head.
5. Remove and discard cylinder head gasket.
6. Repeat above procedures for remaining cylinder head.



### Valves and springs - remove

1. Remove spark plugs.

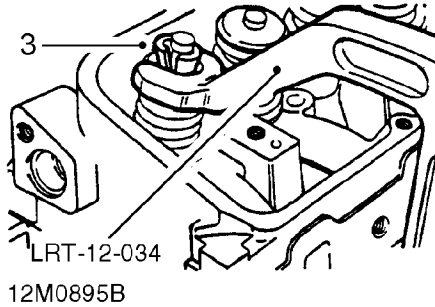

2. Using valve spring compressor **LRT-12-034** or a suitable alternative, compress valve spring.
3. Compress valve spring sufficiently to release collets from valve spring cap.

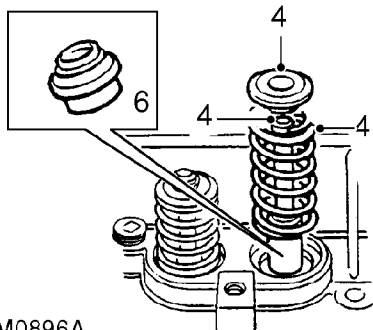

4. Release spring compressor and remove collets, valve, valve spring cap and valve spring.
5. Repeat above operations for remaining valves.



**NOTE:** Keep valves, springs, caps and collets in fitted order.

6. Remove and discard valve stem oil seals.

### Cylinder head - inspection

1. Clean all traces of gasket material from cylinder head using a plastic scraper.
2. Check core plugs for signs of leakage and corrosion, replace as necessary. Apply Loctite 572 to threads of screwed core plugs.

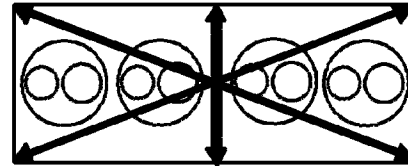

12M2902A

3. Check gasket face of each cylinder head for warping, across centre and from corner to corner.  
Maximum warp = 0.05 mm (0.002 in)

## Valves, valve springs and guides - inspection

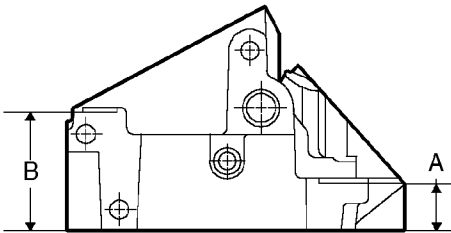
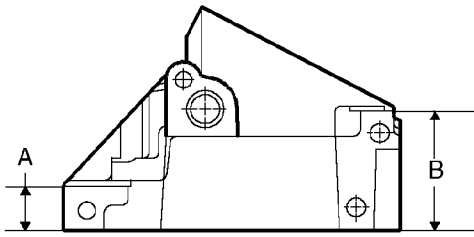

12M4236

4. Check cylinder head height at each end of cylinder head:  
**A**= 22.94 mm (0.903 in) - New  
**B**= 62.56 mm (2.463 in) - New
5. Cylinder heads may be refaced:  
 Reface limit = 0.50 mm (0.02 in) from new dimension

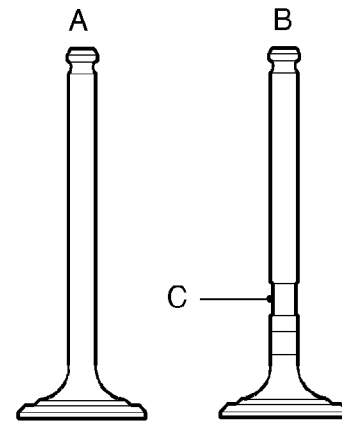

12M3676



**NOTE:** Two types of exhaust valve may be fitted - standard valves **A** in illustration or carbon break valves - **B** in illustration. Carbon break valves may be identified by the machined profile **C** on the valve stem. To prevent exhaust valves sticking, standard exhaust valves should be replaced with carbon break valves during engine overhaul.

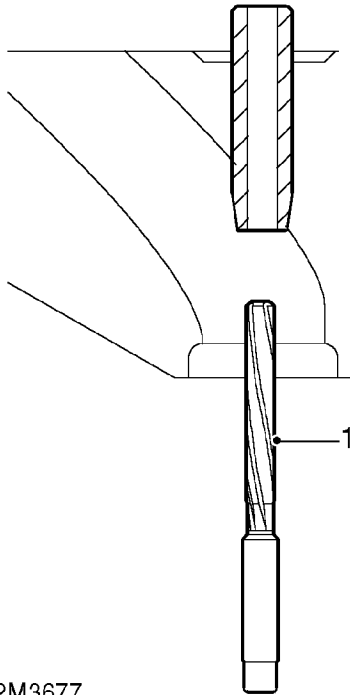

12M3677

1. Remove carbon deposits from valve guides using an 8.70 mm (0.34 in) diameter reamer inserted from combustion face side of cylinder head.
2. Clean valve springs, cotters, caps and valves. Clean inlet valve guide bores. Ensure all loose particles of carbon are removed on completion.
3. Check existing valve stem and head diameters.
4. Check valve stem to guide clearance using new valves.

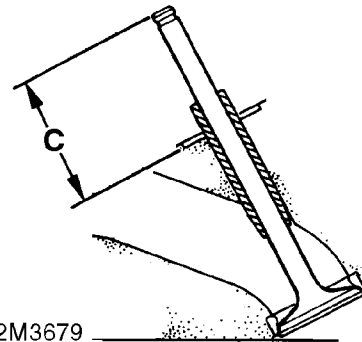
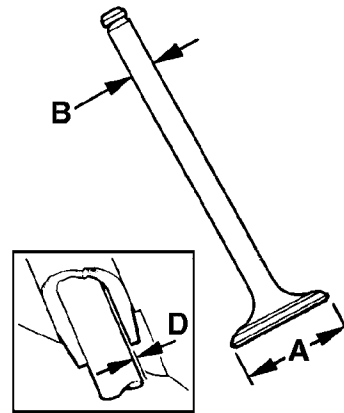

12M3679

5. Renew valves and guides as necessary. Valve head diameter **A**:  
 Inlet = 39.75 to 40.00 mm (1.5 to 1.6 in)  
 Exhaust = 34.226 to 34.48 mm (1.3 to 1.4 in)  
 Valve stem diameter **B**:  
 Inlet = 8.664 to 8.679 mm (0.341 to 0.342 in)  
 Exhaust = 8.651 to 8.666 mm (0.340 to 0.341 in)
6. Check installed height of each valve.  
 Valve installed height **C** = 47.63 mm (1.9 in)
7. Renew valve/valve seat insert as necessary.
8. Check valve stem to guide clearance.  
 Valve stem to guide clearance **D**:  
 Inlet = 0.025 to 0.066 mm (0.001 to 0.002 in)  
 Exhaust = 0.038 to 0.078 mm (0.0015 to 0.003 in)

9. Check condition of valve springs:
  - Free length = 48.30 mm (1.90 in)
  - Fitted length = 40.40 mm (1.60 in)
  - Load - valve closed =  $339 \pm 10$  N ( $76 \pm 2$  lbf)
  - Load - valve open =  $736 \pm 10$  N ( $165 \pm 2$  lbf)



**NOTE:** Valve springs must be replaced as a complete set.

**Valve guides - renew**

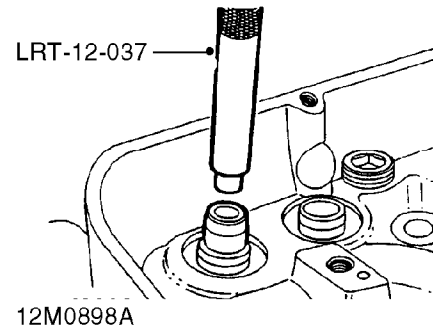

1. Using valve guide remover, **LRT-12-037** press valve guide out into combustion face side of cylinder head.



**NOTE:** Service valve guides are 0.025 mm (0.001 in) oversize on outside diameter to ensure interference fit.

2. Lubricate new valve guide with engine oil and place in position.

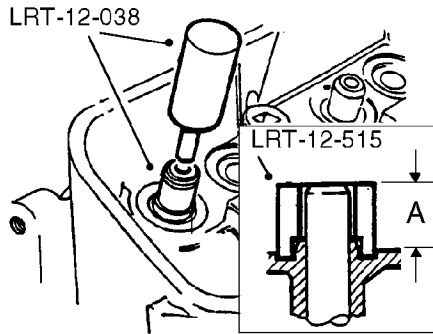

12M0899D

### Valve seat inserts - inspection

1. Check valve seat inserts for pitting, burning and wear. Replace inserts as necessary.

3. Using **LRT-12-038** partially press guide into cylinder head, remove tool.
4. Fit **LRT-12-515** over valve guide and continue to press guide into cylinder head until tool **LRT-12-038** contacts tool **LRT-12-515**; remove tool.  
Valve guide installed height **A** = 15.0 mm (0.590 in)
5. Ream valve guides to 8.70 mm (0.34 in) diameter.
6. Remove all traces of swarf on completion.

# ENGINE

---

## Valve seat inserts - renew

---



**NOTE:** Service valve seat inserts are available 0.025 mm (0.001 in) oversize on outside diameter to ensure interference fit.

1. Remove worn valve seats.



**CAUTION:** Take care not to damage counterbore in cylinder head.

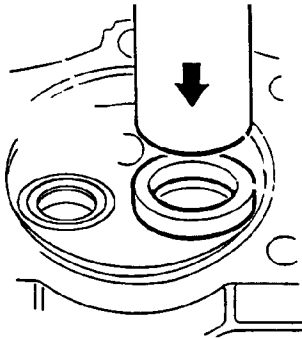

12M3642

2. Heat cylinder head evenly to approximately 120° C (250° F).



**WARNING:** Handle hot cylinder head with care.

3. Using a suitable mandrel, press new insert fully into counterbore.
4. Allow cylinder head to air cool.

## Valve seats and seat inserts - refacing

---



**CAUTION:** Renew worn valve guides and seat inserts before lapping valves to their seats.

1. Check condition of valve seats and valves that are to be re-used.
2. Remove carbon from valve seats.

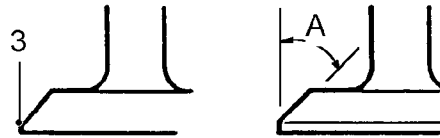

12M0901

3. Reface valves as necessary. If a valve has to be ground to a knife-edge to obtain a true seat, fit a new valve.  
Valve seating face angle **A** = 45°



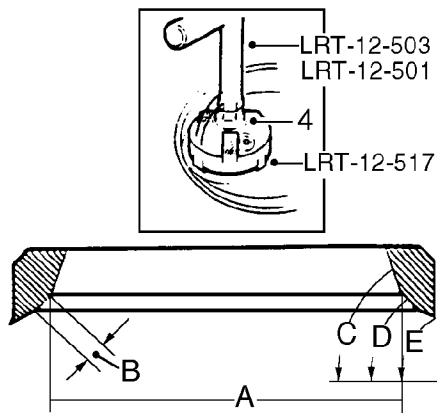

12M0918D

4. Cut valve seats using **LRT-12-501** with **LRT-12-503** and **LRT-12-517**.

Valve seat:

Width **A**:

Inlet = 36.83 mm (1.45 in)

Exhaust = 31.50 mm (1.24 in)

Seating width **B**:

Inlet = 0.89 to 1.4 mm (0.035 to 0.055 in)

Exhaust = 1.32 to 1.83 mm (0.052 to 0.072 in)

Angle **C** = 56° to 70°

Angle **D** = 46° to 46° 25'

Angle **E** = 20°

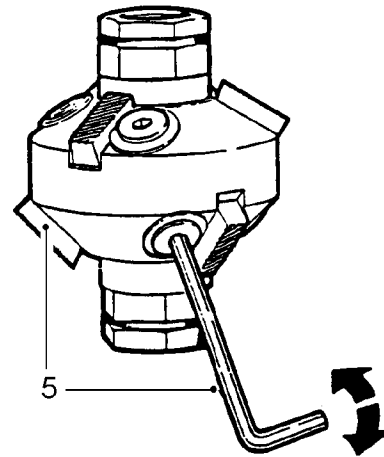

12M0902

5. Ensure cutter blades are correctly fitted to cutter head with angled end of blade downwards, facing work, as illustrated. Check that cutter blades are adjusted so that middle of blade contacts area of material to be cut. Use light pressure and remove only minimum of material necessary.
6. Remove all traces of swarf on completion.

# ENGINE

---

## Valves - lapping-in

---

1. Lap each valve to its seat using fine grinding paste.
2. Clean valve and seat.

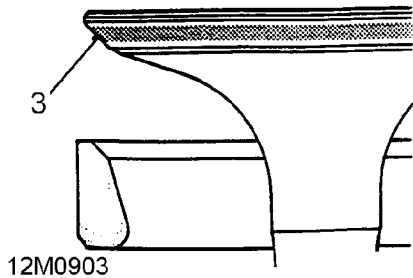

3. Coat valve seat with a small quantity of engineer's blue, insert valve and press it into position several times without rotating. Remove valve and check for even and central seating. Seating position shown by engineer's blue should be in centre of valve face.

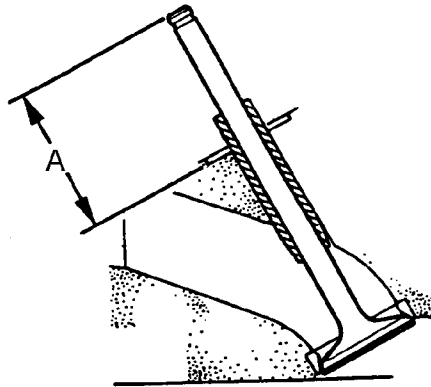

4. Check valve installed height if valve seats have been recut or new valves or valve seat inserts have been fitted.  
Valve installed height  $A = 47.63 \text{ mm (1.9 in)}$  - maximum
5. Thoroughly clean cylinder head, blow out oilways and coolant passages.

## Valves and springs - refit

---

1. Fit new valve stem oil seals, lubricate valve stems, fit valves, valve springs and caps, compress valve springs using **LRT-12-034** and fit collets.
2. Using a wooden dowel and mallet, lightly tap each valve stem two or three times to seat valve cap and collets.
3. Fit spark plugs and tighten to 20 Nm (15 lbf.ft).



### Cylinder head - refit

1. Clean cylinder block and cylinder head faces using suitable gasket removal spray and a plastic scraper.
2. Ensure that bolt holes in cylinder block are clean and dry.



**CAUTION:** Do not use metal scraper or machined surfaces may be damaged.

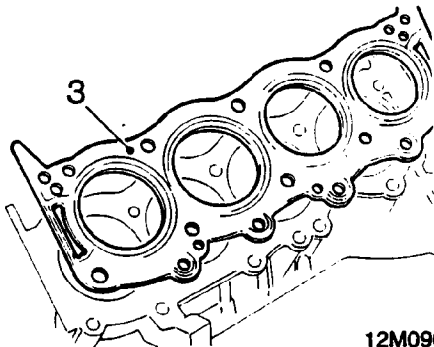

12M0905

3. Fit cylinder head gasket with the word 'TOP' uppermost.



**NOTE:** Gasket must be fitted dry.

4. Carefully fit cylinder head and locate on dowels.

5. Lightly oil threads of new cylinder head bolts.

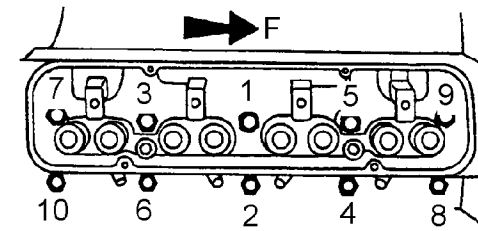

12M1248A



**NOTE:** RH cylinder head illustrated.

6. Fit new cylinder head bolts:  
Long bolts: 1, 3 and 5  
Short bolts: 2, 4, 6, 7, 8, 9 and 10
7. Using sequence shown, tighten cylinder head bolts to:  
Stage 1 - 20 Nm (15 lbf.ft)  
Stage 2 - 90 degrees  
Stage 3 - Further 90 degrees



**CAUTION:** Do not tighten bolts 180° in one operation.

8. Fit rocker shaft assembly.
9. Repeat above procedures for remaining cylinder head.

# ENGINE

## TIMING CHAIN AND GEARS

### Sump - remove

1. Remove dipstick.

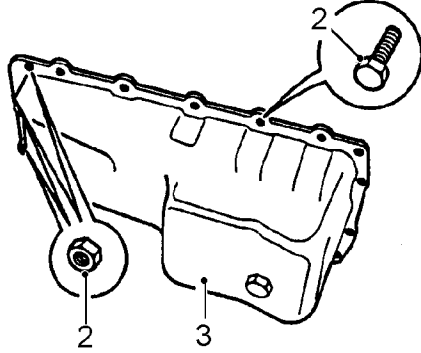

12M1377A

2. Remove 14 bolts and 3 nuts securing sump to cylinder block and timing cover.
3. Taking care not to damage sealing faces, carefully release sump from timing cover and cylinder block.
4. Remove sump.

### Timing cover - remove



**NOTE:** Timing cover, oil pump and oil pressure relief valve are only supplied as an assembly.

1. Using assistance, restrain flywheel/drive plate and remove crankshaft pulley bolt; collect spacer washer - if fitted.
2. Remove crankshaft pulley.
3. Remove sump.

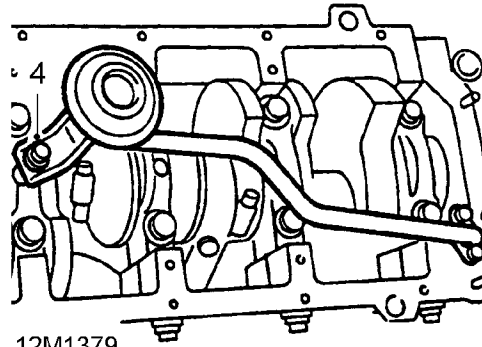

12M1379

4. Remove nut and washers securing oil pick-up pipe to stud.

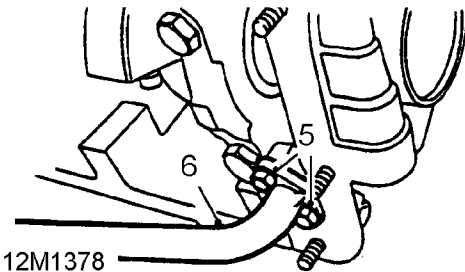

12M1378

5. Remove 2 bolts securing oil pick-up pipe to oil pump cover, withdraw pipe from cover; remove and discard 'O' ring.
6. Remove oil pick-up pipe, recover spacer from stud.

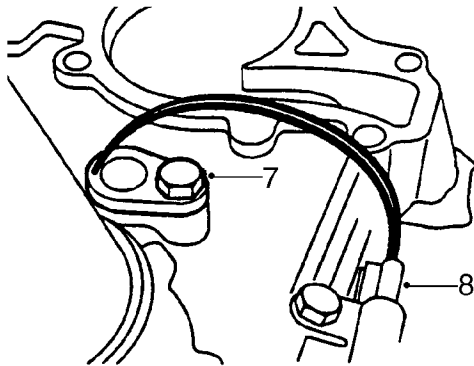

12M1380A

7. Remove bolt securing camshaft sensor to timing cover, withdraw sensor; remove and discard 'O' ring.
8. Release harness connector from mounting bracket.

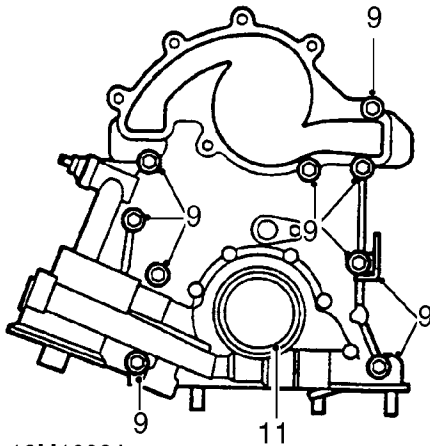

12M1383A



**NOTE:** New Range Rover timing cover illustrated.

9. Noting their fitted position, remove 9 bolts securing timing cover to cylinder block; remove cover; collect camshaft sensor harness mounting bracket.



**NOTE:** Timing cover is dowel located.



**CAUTION:** Do not attempt to remove oil pump drive gear at this stage.

10. Remove and discard gasket.
11. Remove and discard oil seal from timing cover.

### Timing gears - remove

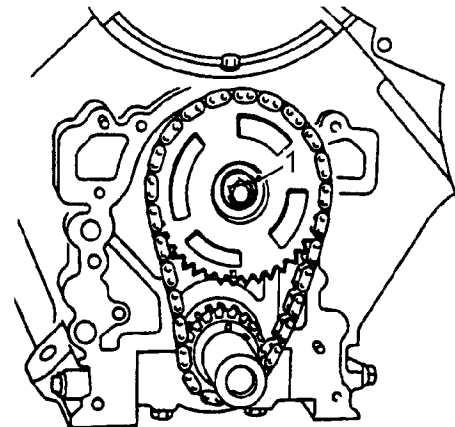

12M1396A

1. Restrain camshaft gear and remove bolt securing gear.

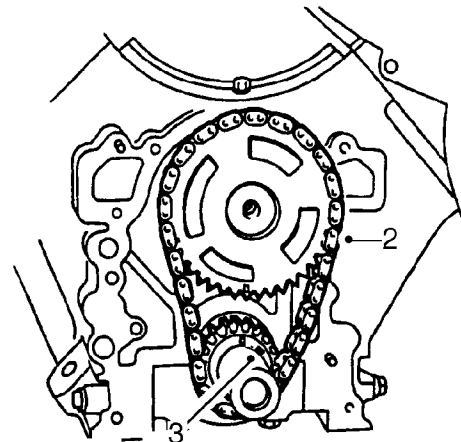

12M1397

2. Remove timing chain and gears as an assembly.
3. Collect Woodruff key from crankshaft.

# ENGINE

---

## Timing chain and gears - inspection

---

1. Thoroughly clean all components.
2. Inspect timing chain links and pins for wear.
3. Inspect timing chain gears for wear. Replace components as necessary.

## Timing gears - refit

---

1. Clean gear locations on camshaft and crankshaft, fit Woodruff key to crankshaft.

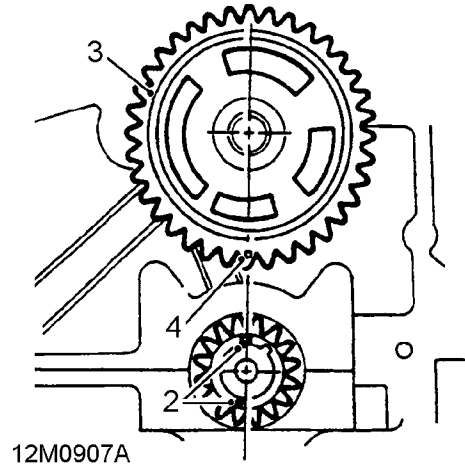

2. Temporarily fit crankshaft gear and if necessary, turn crankshaft to bring timing mark on gear to the twelve o'clock position, remove gear.
3. Temporarily fit camshaft gear.
4. Turn camshaft until mark on camshaft sprocket is at the six o'clock position, remove gear without moving camshaft.

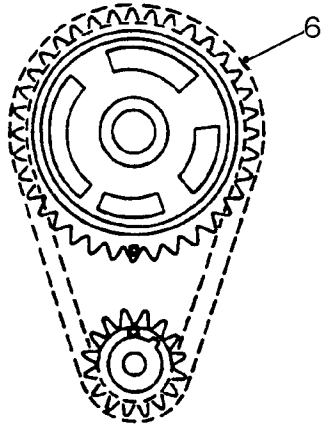

12M0914A

5. Position timing gears on work surface with timing marks aligned.
6. Fit timing chain around gears, keeping timing marks aligned.
7. Fit gear and chain assembly.



**NOTE:** Timing marks must be facing forwards.

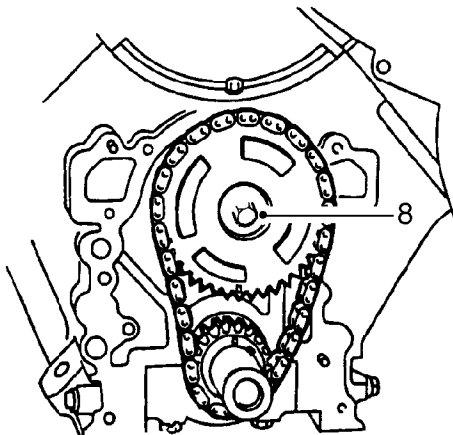

12M1399A

8. Fit camshaft gear bolt, restrain camshaft gear and tighten bolt to 50 Nm (37 lbf.ft).

### Timing cover - refit



**NOTE:** Timing cover, oil pump and oil pressure relief valve are only supplied as an assembly.

1. Clean sealant from threads of timing cover bolts.
2. Clean all traces of gasket material from mating faces of timing cover and cylinder block.



**CAUTION:** Use a plastic scraper.

3. Clean oil seal location in timing cover.
4. Lubricate oil pump gears and oil seal recesses in timing cover with engine oil.
5. Apply Hylosil jointing compound to new timing cover gasket, position gasket to cylinder block.

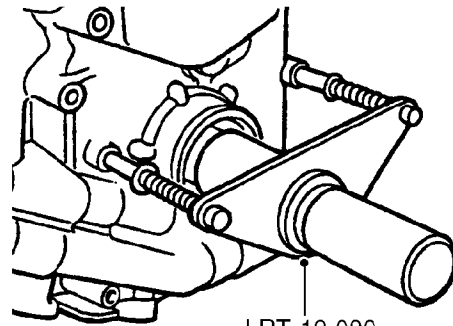

12M1253B

LRT-12-090

6. Locate tool **LRT-12-090** on timing cover and oil pump drive gear.
7. Position timing cover to cylinder block and at the same time, rotate tool **LRT-12-090** until drive gear keyway is aligned with Woodruff key.
8. Fit timing cover to cylinder block.

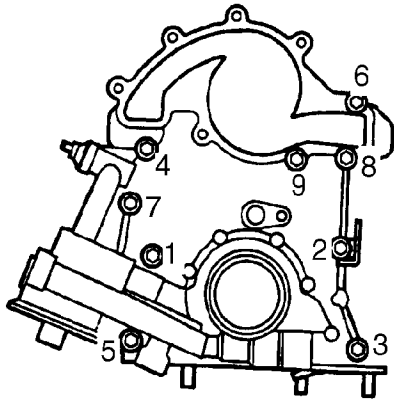

12M1398



**NOTE:** New Range Rover timing cover illustrated.

9. Position camshaft sensor harness mounting bracket to timing cover ensuring that bracket is positioned parallel to crankshaft centre line. Fit bolts and tighten in sequence shown to 22 Nm (16 lbf.ft).



**CAUTION:** Do not fit coolant pump bolts at this stage.

10. Remove tool LRT-12-090.

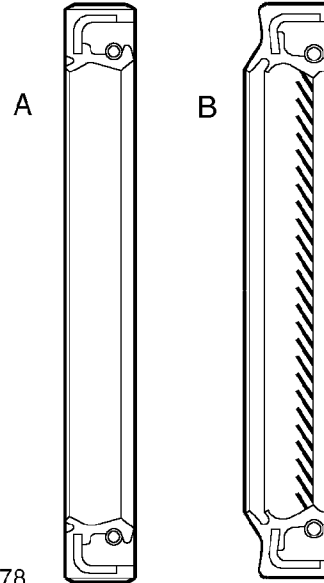

12M3678

- A- Early type seal
- B- Later type seal - use as replacement on all engines

11. Lubricate new timing cover oil seal with Shell Retinax LX grease ensuring that space between seal lips is filled with grease.



**CAUTION:** Do not use any other type of grease.



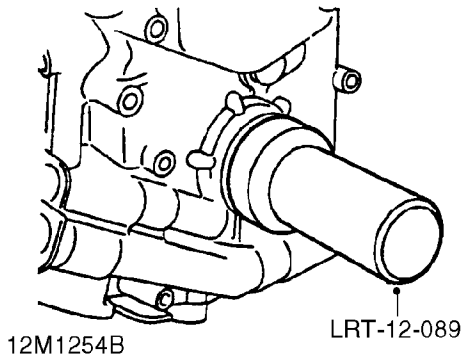

12. Fit timing cover oil seal using tool **LRT-12-089**.
13. Smear a new 'O' ring with engine oil and fit to oil pick-up pipe.
14. Position oil pick-up pipe spacer on number 4 main bearing cap stud.
15. Fit oil pick-up pipe ensuring that end of pipe is correctly inserted in oil pump body.
16. Fit oil pick-up pipe to oil pump body bolts and tighten to 8 Nm (6 lbf.ft).
17. Fit washers and nut securing oil pick-up pipe to stud, tighten nut to 24 Nm (18 lbf.ft).
18. Smear a new 'O' ring with engine oil and fit to camshaft sensor.
19. Insert camshaft sensor into timing cover, fit bolt and tighten to 8 Nm (6 lbf.ft).
20. Position camshaft sensor harness connector on mounting bracket.
21. Fit sump.
22. Fit crankshaft pulley, fit bolt and spacer washer - if fitted; tighten bolt to 270 Nm (200 lbf.ft).



**NOTE:** Crankshaft pulleys which incorporate a mud flinger can be fitted to all engines.

### Sump - refit

1. Remove all traces of old sealant from mating faces of cylinder block and sump.

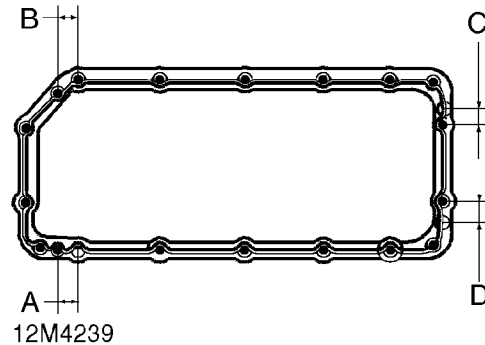

2. Clean mating faces with suitable solvent and apply a bead of Hylosil Type 101 or 106 sealant to sump joint face as shown:  
 Bead width - areas A, B, C and D = 12 mm (0.5 in)  
 Bead width - remaining areas = 5 mm (0.20 in)  
 Bead length - areas A and B = 32 mm (1.23 in)  
 Bead length - areas C and D = 19 mm (0.75 in)



**CAUTION:** Do not spread sealant bead. Sump must be fitted immediately after applying sealant.

3. Fit sump, taking care not to damage sealant bead.

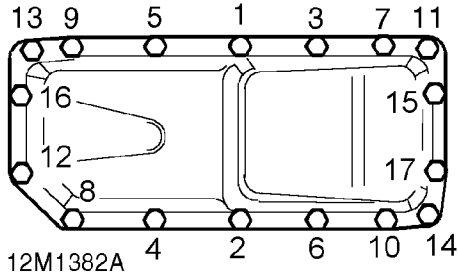

4. Fit sump bolts and nuts and working in sequence shown, tighten to 23 Nm (17 lbf.ft).
5. Fit sump drain plug and tighten to 45 Nm (33 lbf.ft).
6. Fit dipstick.

## OIL PUMP AND OIL PRESSURE RELIEF VALVE



**NOTE:** Overhaul procedures for the oil pump and oil pressure relief valve are limited to carrying out dimensional checks. In the event of wear or damage being found, a replacement timing cover and oil pump assembly must be fitted.

### Oil pump - remove

1. Remove timing cover.



**CAUTION:** Do not attempt to remove oil pump drive gear from inner rotor at this stage.

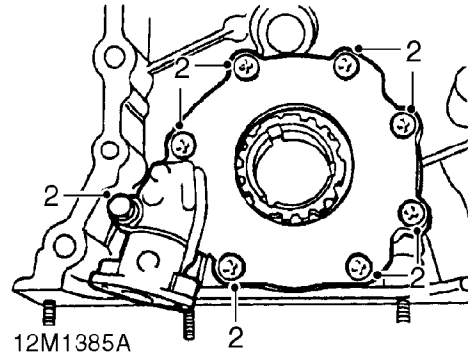

2. Remove 7 screws and bolt securing oil pump cover plate, remove plate.

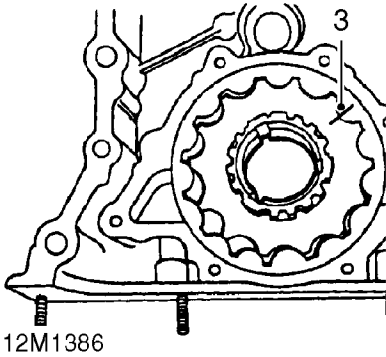

12M1386

3. Make suitable alignment marks on inner and outer rotors, remove rotors and oil pump drive gear as an assembly.

### Oil pressure relief valve - remove

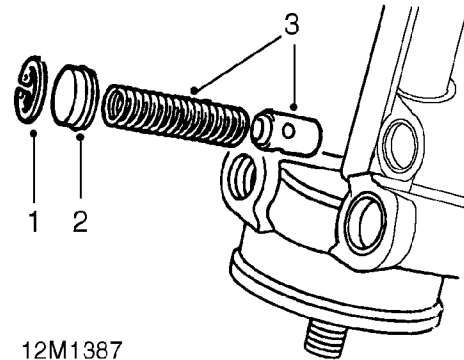

12M1387

1. Remove circlip.
2. Remove relief valve plug, remove and discard 'O' ring.
3. Remove relief valve spring and piston.

# ENGINE

## Oil pump - inspection

1. Thoroughly clean oil pump drive gear, cover plate, rotors and housing. Remove all traces of Loctite from cover plate securing screws; ensure tapped holes in timing cover are clean and free from oil.
2. Check mating surfaces of cover plate, rotors and housing for scoring.
3. Assemble rotors and oil pump drive gear in housing ensuring that reference marks are aligned.

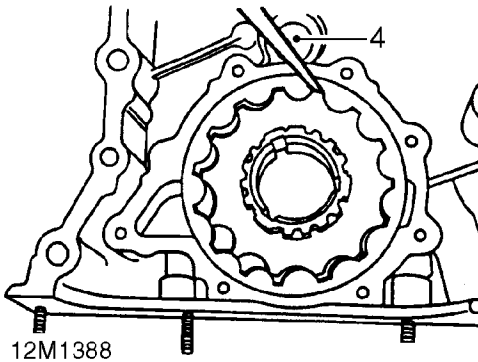

4. Using feeler gauges, check clearance between teeth of inner and outer rotors:  
Maximum clearance = 0.25 mm (0.01 in)

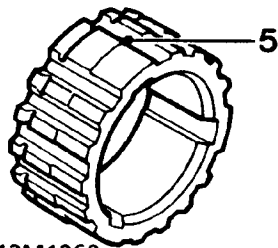

5. Remove oil pump drive gear, check depth of any wear steps on gear teeth:  
Wear step maximum depth = 0.15 in (0.006 in)

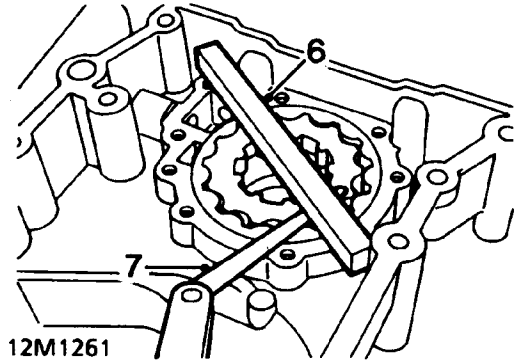

6. Place a straight edge across housing.
7. Using feeler gauges, check clearance between straight edge and rotors:  
Maximum clearance = 0.1 mm (0.004 in).



---

### Oil pressure relief valve - inspection

---

1. Clean relief valve components and piston bore in timing cover.
2. Check piston and bore for scoring and that piston slides freely in bore with no perceptible side movement.
3. Check relief valve spring for damage and distortion; check spring free length:  
Spring free length = 60.0 mm (2.4 in).

---

### Oil pump - refit

---

1. Lubricate rotors, oil pump drive gear, cover plate and housing with engine oil.
2. Assemble rotors and drive gear in housing ensuring that reference marks are aligned.
3. Position cover plate to housing.
4. Apply Loctite 222 to threads of cover plate screws and bolt.
5. Fit cover plate screws and bolt and tighten to:-  
Screws - 4 Nm (3 lbf.ft)  
Bolt - 8 Nm (6 lbf.ft)
6. Fit timing cover.

# ENGINE

---

## Oil pressure relief valve - refit

---

1. Lubricate new 'O' ring with engine oil and fit to relief valve plug.
2. Lubricate relief valve spring, piston and piston bore with engine oil.
3. Assemble piston to relief valve spring, insert piston and spring into piston bore.
4. Fit relief valve plug, depress plug and fit circlip.
5. Ensure circlip is fully seated in groove.

## CAMSHAFT AND TAPPETS

---

### Camshaft end-float - check

---

1. Remove rocker shaft assemblies.
2. Remove pushrods and store in their fitted order.
3. Remove timing chain and gears.

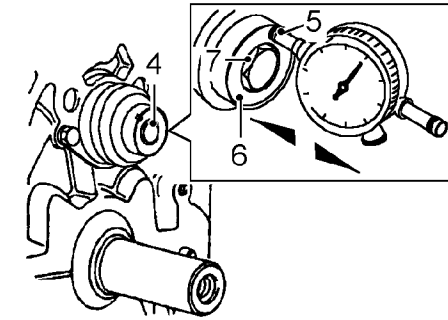

12M3650

4. Temporarily fit camshaft gear bolt.
5. Attach a suitable DTI to front of cylinder block with stylus of gauge contacting end of camshaft.
6. Push camshaft rearwards and zero gauge.
7. Using camshaft gear bolt, pull camshaft forwards and note end-float reading on gauge.  
End-float = 0.05 to 0.35 mm (0.002 to 0.014 in)
8. If end-float is incorrect, fit a new thrust plate and re-check. If end-float is still incorrect, a new camshaft must be fitted.



### Camshaft and tappets - remove

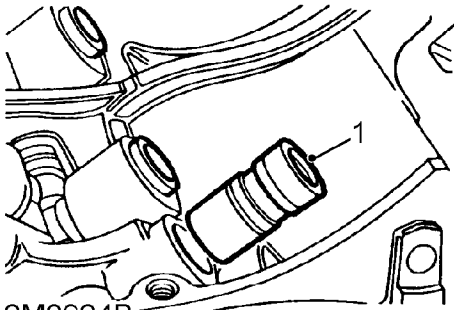

12M0924B

1. Remove tappets and retain with their respective pushrods.

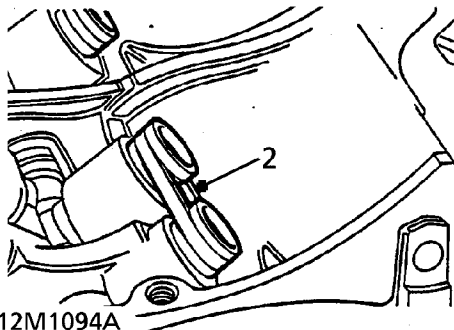

12M1094A

2. When tappets prove difficult to remove due to damaged camshaft contact area, proceed as follows. Lift tappets in pairs to the point where damaged face is about to enter tappet bore and fit rubber bands to retain tappets. Repeat until all tappets are retained clear of camshaft lobes. The tappets can then be withdrawn out the bottom of their bores when the sump and camshaft are removed.

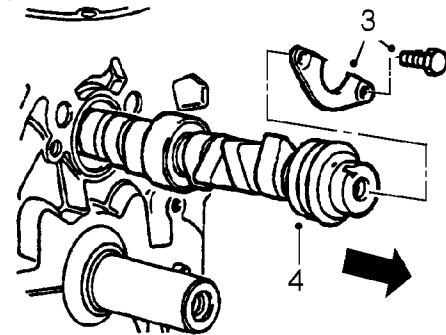

12M3651A

3. Remove 2 bolts securing camshaft thrust plate to cylinder block, remove plate.
4. Withdraw camshaft, taking care not to damage bearings in cylinder block.



**NOTE:** Camshafts fitted to 4.0 litre engines are colour coded **ORANGE** whilst those fitted to 4.6 litre engines are colour coded

**RED.**

## Camshaft and tappets - inspection

---

1. Thoroughly clean all components.
2. Inspect camshaft bearing journals and lobes for signs of wear, pitting, scoring and overheating.
3. Support camshaft front and rear bearings on vee blocks, and using a DTI, measure camshaft run-out on centre bearing:  
Maximum permitted run-out = 0.05 mm (0.002 in)
4. Inspect thrust plate for wear, replace plate if wear is evident.
5. Clean and inspect tappets. Check for an even, circular wear pattern on the camshaft contact area. If contact area is pitted or a square wear pattern has developed, tappet must be renewed.
6. Inspect tappet body for excessive wear or scoring. Replace tappet if scoring or deep wear patterns extend up to oil feed area. Clean and inspect tappet bores in cylinder block.
7. Ensure that tappets rotate freely in their respective bores.
8. Inspect pushrod contact area of tappet, replace tappet if surface is rough or pitted.

## Camshaft and tappets - refit

---



**NOTE:** If a replacement camshaft is to be fitted, ensure colour coding is correct.

Camshafts fitted to 4.0 litre engines are colour coded **ORANGE** whilst those fitted to 4.6 litre engines are colour coded **RED**.

1. Lubricate camshaft journals with engine oil and carefully insert camshaft into cylinder block.
2. Fit camshaft thrust plate, fit bolts and tighten to 25 Nm (18 lbf.ft).



**NOTE:** If camshaft or thrust plate has been replaced, it will be necessary to re-check camshaft end-float.

3. Immerse tappets in engine oil. Before fitting, pump the inner sleeve of tappet several times using a pushrod to prime tappet; this will reduce tappet noise when engine is first started.
4. Lubricate tappet bores with engine oil and fit tappets in removed order.



**NOTE:** Some tappet noise may still be evident on initial start-up. If necessary, run the engine at 2500 rev/min for a few minutes until noise ceases.

5. Fit timing chain and gears.
6. Fit rocker shaft assemblies.





---

**PISTONS, CONNECTING RODS, PISTON RINGS  
AND CYLINDER BORES**

---

---

**Pistons and connecting rods - remove**

---

1. Remove cylinder head(s).
2. Remove big-end bearings.
3. Remove carbon ridge from top of each cylinder bore.
4. Suitably identify each piston to its respective cylinder bore.
5. Push connecting rod and piston assembly to top of cylinder bore and withdraw assembly.
6. Repeat above procedure for remaining pistons.



**CAUTION: Big-end bearing shells must be replaced whenever they are removed.**

---

**Piston rings - remove**

---

1. Using a suitable piston ring expander, remove and discard piston rings.
2. Remove carbon from piston ring grooves.



**NOTE: Use an old broken piston ring with a squared-off end.**



**CAUTION: Do not use a wire brush.**

# ENGINE

## Piston rings - inspection

1. Temporarily fit new compression rings to piston.



**NOTE:** If replacement pistons are to be fitted, ensure rings are correct for piston.

The 2nd compression ring marked 'TOP' must be fitted, with marking uppermost, into second groove. The 1st compression ring fits into top groove and can be fitted either way round.

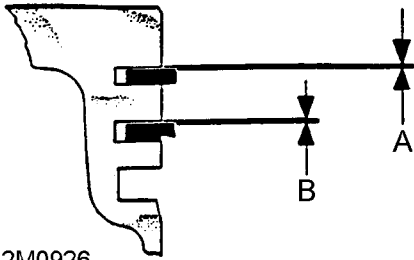

12M0926

2. Check compression ring to groove clearance:  
1st compression ring **A** = 0.05 to 0.10 mm (0.002 to 0.004 in).  
2nd compression ring **B** = 0.05 to 0.10 mm (0.002 to 0.004 in).

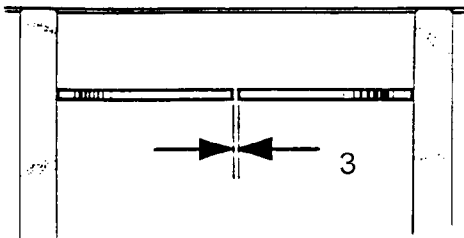

12M0927

3. Insert piston ring into its relevant cylinder bore, held square to bore with piston and check ring gaps.  
1st compression ring = 0.3 to 0.5 mm (0.01 to 0.02 in)  
2nd compression ring = 0.40 to 0.65 mm (0.016 to 0.03 in)  
Oil control ring rails = 0.38 to 1.40 mm (0.014 to 0.05 in)
4. Retain rings with their respective pistons.

## Pistons- remove

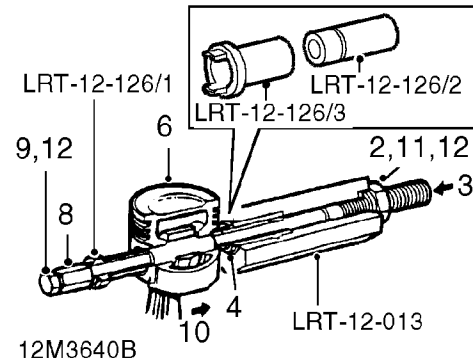

1. Clamp hexagon body of **LRT-12-013** in vice.
2. Screw large nut back until flush with end of centre screw.
3. Push centre screw forward until nut contacts thrust race.
4. Locate remover/replacer adapter **LRT-12-126/2** with its long spigot inside bore of hexagon body.
5. Position remover/replacer adapter **LRT-12-126/3** on **LRT-12-126/2** with cut-out facing away from body of **LRT-12-013**.
6. Locate piston and connecting rod assembly on centre screw and up to adapter **LRT-12-126/2**.
7. Position cut-out of adapter **LRT-12-126/3** to piston.



**CAUTION:** Ensure cut-out does not contact gudgeon pin.

8. Fit remover/replacer bush **LRT-12-126/1** on centre screw with flanged end away from gudgeon pin. Screw stop nut on to centre screw.
9. Lock the stop nut securely with lockscrew.
10. Push connecting rod to right to locate end of gudgeon pin in adapter **LRT-12-126/2**.
11. Screw large nut up to **LRT-12-013**.
12. Hold lockscrew and turn large nut until gudgeon pin is withdrawn from piston.
13. Dismantle tool and remove piston, connecting rod and gudgeon pin.



**NOTE:** Keep each piston and gudgeon pin with their respective connecting rod.

14. Repeat above operation for remaining pistons.



## Pistons - inspection

1. Clean carbon from pistons.
2. Inspect pistons for distortion, cracks and burning.

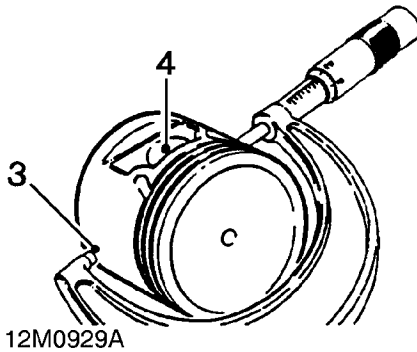

3. Measure and record piston diameter at 90° to gudgeon pin axis and 10 mm (0.4 in) from bottom of skirt.
4. Check gudgeon pin bore in piston for signs of wear and overheating.



**NOTE:** Pistons fitted on production are graded 'A' or 'B,' the grade letter is stamped on the piston crown.

### Production piston diameter:

Grade **A** = 93.970 to 93.985 mm (3.700 to 3.7002 in)

Grade **B** = 93.986 to 94.00 mm (3.7003 to 3.701 in)

Grade **B** pistons are supplied as service replacements. Worn cylinder liners fitted with grade 'A' pistons may be honed to accept grade 'B' pistons provided that specified cylinder bore and ovality limits are maintained.



**CAUTION:** Ensure replacement pistons are correct for the compression ratio of the engine. The compression ratio will be found on the cylinder block above the engine serial number. Ensure that replacement connecting rods are correct length for engine being overhauled.

### Connecting rod length between centres:

4.0 litre = 155.12 to 155.22 mm (6.10 to 6.11 in)

4.6 litre = 149.68 to 149.78 mm (5.89 to 5.91 in)

## Gudgeon pins - inspection



**NOTE:** Gudgeon pins are only supplied as an assembly with replacement pistons.

1. Check gudgeon pins for signs of wear and overheating.
2. Check clearance of gudgeon pin in piston.  
Gudgeon pin to piston clearance = 0.006 to 0.015 mm (0.0002 to 0.0006 in).
3. Check overall dimensions of gudgeon pin.  
Overall length = 60.00 to 60.50 mm (2.35 to 2.4 in).  
Diameter - measured at each end and centre of pin = 23.995 to 24.00 mm (0.94 to 0.95 in).

## ENGINE

---

### Cylinder liner bore - inspection

---

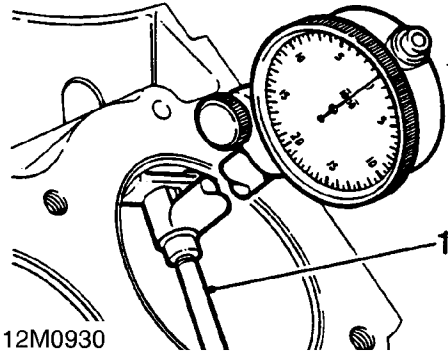

2. If only new piston rings are to be fitted, break cylinder bore glazing using a fine grit, to produce a 60° cross-hatch finish. Ensure all traces of grit are removed after above operation.
3. Check alignment of connecting rods.

1. Measure cylinder liner bore wear and ovality in two axis 40 to 50 mm (1.5 to 1.9 in) from top of bore.

Cylinder liner bore:

Grade 'A' piston fitted = 94.00 to 94.015 mm  
(3.700 to 3.701 in)

Grade 'B' piston fitted = 94.016 to 94.030 mm  
(3.7014 to 3.702 in)

Maximum ovality = 0.013 mm (0.0005 in)

Cylinder liners having grade 'A' pistons fitted may be honed to accept grade 'B' pistons provided specified wear and ovality limits are maintained.



**CAUTION:** The temperature of piston and cylinder block must be the same to ensure accurate measurement.



## Pistons - refit



**CAUTION:** Pistons have a 0.5 mm (0.02 in) offset gudgeon pin which can be identified by an arrow mark on the piston crown.

This arrow **MUST** always point to the front of the engine.

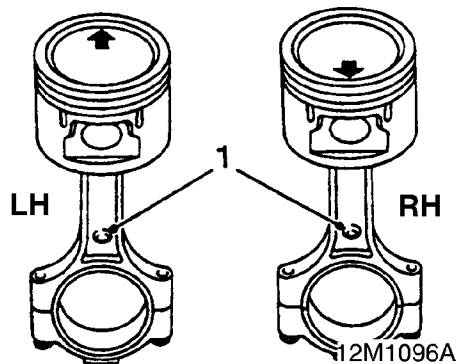

1. Assemble pistons to connecting rods with arrow on piston pointing towards domed shaped boss on connecting rod for RH bank of cylinders, and arrow pointing away from dome shaped boss for LH bank of cylinders.

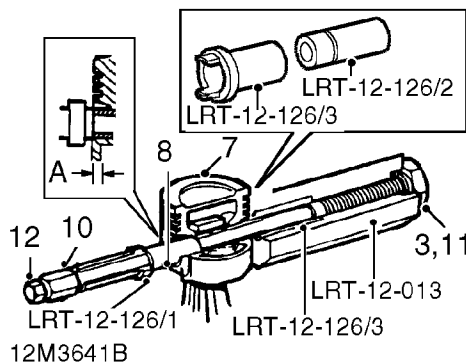

2. Clamp hexagon body of **LRT-12-013** in vice.
3. Slacken large nut and pull the centre screw 50.8 mm (2.0 in) out of hexagon body.
4. Locate remover/replacer adapter **LRT-12-126/2** with its long spigot inside bore of hexagon body.
5. Fit remover/replacer adapter **LRT-12-126/3** with cut-out towards piston, up to shoulder on centre screw.
6. Lubricate gudgeon pin and bores of connecting rod and piston with graphited oil.

7. Locate connecting rod and piston to centre screw with connecting rod entered on sleeve up to groove.
8. Fit gudgeon pin on to centre screw and into piston bore up to connecting rod.
9. Fit remover/replacer bush **LRT-12-126/1** with flanged end towards gudgeon pin.
10. Screw the stop nut onto centre screw and position piston against cut-out of adapter **LRT-12-126/3**.
11. Lubricate centre screw threads and thrust race with graphited oil, screw large nut up to **LRT-12-013**.
12. Lock the stop nut securely with lockscrew.
13. Set torque wrench to 16 Nm (12 lbf.ft), and using socket on large nut, pull gudgeon pin in until flange of **LRT-12-126/1** is distance **A** from face of piston.  
Distance **A** = 0.4 mm (0.016 in).



**CAUTION:** If torque wrench 'breaks' during above operation, fit of gudgeon pin to connecting rod is not acceptable and components must be replaced. The centre screw and thrust race must be kept well lubricated throughout operation.

14. Dismantle tool, remove piston, check no damage has occurred during pressing and piston moves freely on gudgeon pin.
15. Repeat above operations for remaining pistons.

# ENGINE

## Piston to cylinder bore clearance - checking

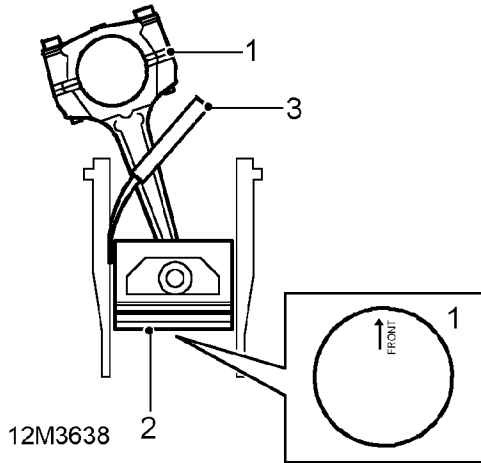

1. Starting with number 1 piston, invert piston and with arrow on piston crown pointing towards REAR of cylinder block, insert piston in cylinder liner.
2. Position piston with bottom of skirt 30 mm (1.2 in) from top of cylinder block.
3. Using feeler gauges, measure and record clearance between piston and left hand side of cylinder - viewed from front of cylinder block: Piston to bore clearance = 0.02 to 0.045 mm (0.001 to 0.002 in)
4. Repeat above procedures for remaining pistons.

## Pistons and connecting rods - refit

1. Fit oil control ring rails and expander, ensuring ends butt and do not overlap.

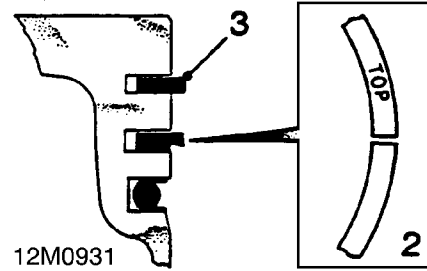

2. Fit 2nd compression ring marked 'TOP' with marking uppermost into second groove.
3. Fit 1st compression ring into first groove either way round.

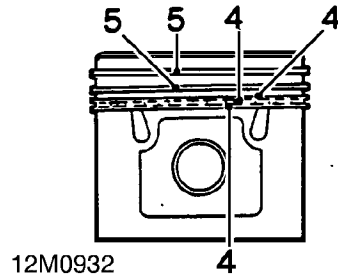

4. Position oil control expander ring joint and ring rail gaps all at one side, between gudgeon pin and away from left hand (thrust) side of piston - viewed from front of piston. Space gaps in ring rails approximately 25 mm (1.0 in) each side of expander ring joint.
5. Position compression rings with ring gaps on opposite sides of piston between gudgeon pin and right hand side of piston - viewed from front of piston.
6. Thoroughly clean cylinder bores.
7. Lubricate piston rings and gudgeon pin with engine oil.
8. Lubricate cylinder bores with engine oil.



---

**FLYWHEEL AND STARTER RING GEAR**



---



---

**Flywheel - remove**

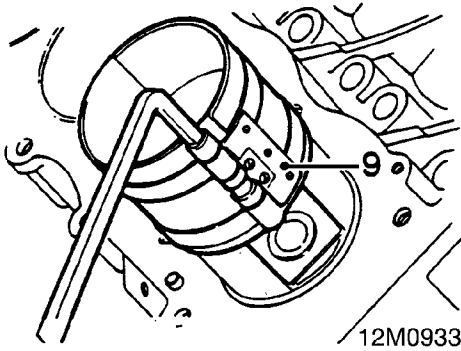
---



9. Fit ring clamp to piston and compress piston rings.

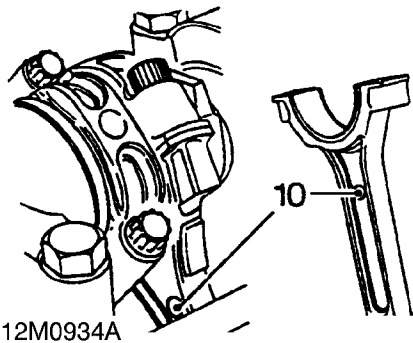

△ **NOTE:** Connecting rods shown in final fitted positions.

10. Insert connecting rod and piston assembly into respective cylinder bore ensuring domed shaped boss on connecting rod faces towards front of engine on RH bank of cylinders, and towards rear on LH bank of cylinders.
11. Fit big-end bearing caps and bearing shells.
12. Fit cylinder head(s).

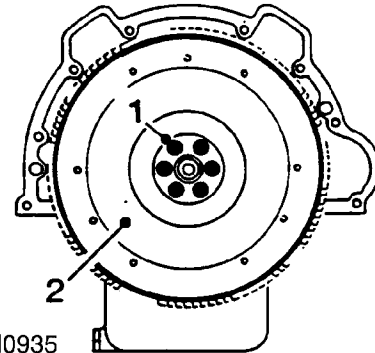

1. Restrain crankshaft and remove 6 bolts securing flywheel.
2. Remove flywheel.



**NOTE:** Dowel located

# ENGINE

## Flywheel and starter ring gear - inspection

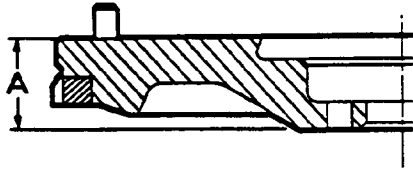

12M0936

1. Inspect flywheel face for cracks, scores and overheating. The flywheel can be refaced on the clutch face providing thickness does not go below minimum.  
Flywheel minimum thickness **A** = 40.45 mm (1.6 in)
2. Inspect starter ring gear for worn, chipped and broken teeth.



**CAUTION: Do not attempt to remove reluctor ring.**

3. Renew starter ring gear if necessary.

## Starter ring gear - renew

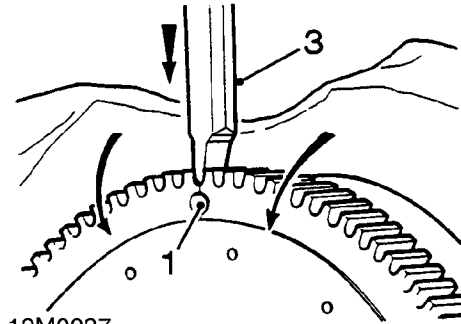

12M0937

1. Drill a 6 mm (0.250 in) diameter hole at root of 2 teeth.



**CAUTION: Do not allow drill to enter flywheel.**

2. Secure flywheel in soft jawed vice.
3. Split ring gear using a cold chisel.



**WARNING: Wear safety goggles and take precautions against flying fragments when splitting ring gear.**

4. Remove flywheel from vice, remove old ring gear, and place flywheel, clutch side down, on a flat surface.



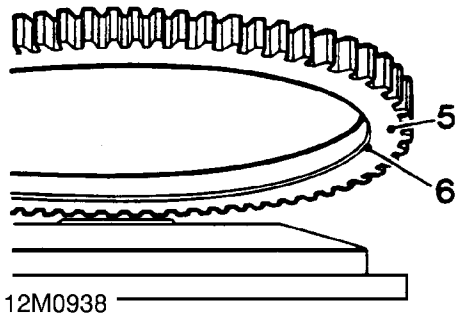

### Flywheel - refit

1. Fit flywheel and locate on 2 dowels.
2. Fit flywheel bolts.
3. Using assistance, restrain crankshaft and tighten flywheel bolts to 80 Nm (59 lbf.ft).

5. Heat new ring gear uniformly to between 170° and 175° C (340° and 350° F).



**CAUTION:** Do not exceed this temperature.



**WARNING:** Take care when handling hot ring gear.

6. Locate ring gear on flywheel with chamfered inner diameter towards flywheel flange.



**NOTE:** If ring gear is chamfered on both sides, it can be fitted either way round.

7. Press ring gear on to flywheel until it butts against flywheel flange.
8. Allow flywheel to air cool.

# ENGINE

## DRIVE PLATE AND RING GEAR ASSEMBLY

### Drive plate and ring gear assembly - remove - Up to engine nos. 42D00593A and 46D00450A

1. Suitably identify each component to its fitted position.

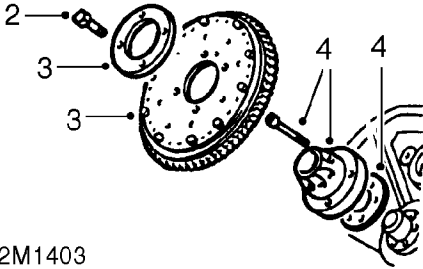

NOTE: 4.0 litre drive plate illustrated.

2. Remove 4 bolts securing drive plate assembly.
3. Remove buttness ring and drive plate assembly.

NOTE: Drive plate assembly is dowel located.

4. Remove 6 socket head cap screws securing hub aligner to crankshaft, remove hub aligner and selective shim; retain shim.

NOTE: Dowel located.

### Drive plate and ring gear assembly - remove - From engine nos. 42D00594A, 46D00451A and all engines having serial no. prefixes 47D to 51D

1. Suitably identify each component to its fitted position.

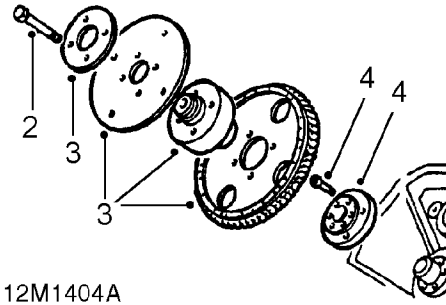

NOTE: 4.0 litre drive plate illustrated.

2. Remove 4 bolts securing buttness ring, drive plate, spacer and ring gear assembly to hub aligner.
3. Remove buttness ring, drive plate, spacer and ring gear assembly.

NOTE: Ring gear assembly is dowel located.

4. Remove 6 socket head cap screws securing hub aligner to crankshaft, remove hub aligner.

NOTE: Dowel located.



### Drive plate and ring gear - inspection

1. Inspect drive plate for cracks and distortion.
2. Renew drive plate if necessary.
3. Inspect ring gear for worn, chipped and broken teeth.
4. Renew ring gear assembly if necessary.

### Drive plate and ring gear assembly - refit - Up to engine nos. 42D00593A and 46D00450A



**CAUTION:** To prevent distortion to drive plate when bolted to torque converter, drive plate setting height must be checked as follows:

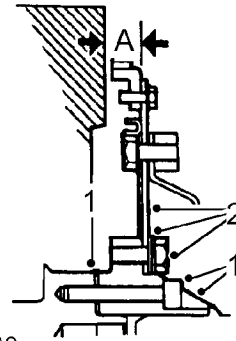

12M1402

1. Fit original selective shim and hub aligner, fit socket head cap screws and tighten to 85 Nm (63 lbf.ft).
2. Fit drive plate assembly and butress ring ensuring that reference marks are aligned; fit bolts and tighten to 45 Nm (33 lbf.ft).



**CAUTION:** If a new drive plate assembly is being fitted, paint mark on plate must face towards torque converter.

3. Check the setting height **A**.  
Up to engine no. 42D00593A = 21.25 to 21.37 mm (0.83 to 0.84 in)  
Up to engine no. 46D00450A = 7.69 to 7.81 mm (0.30 to 0.31 in)
4. If setting height is not as specified, remove butress ring, drive plate assembly, hub aligner and selective shim.

5. Measure existing shim and, if necessary, select appropriate shim to achieve setting height.

Shims available:

- 1.20 - 1.25mm (0.048 to 0.050 in)
  - 1.30 - 1.35mm (0.051 to 0.053 in)
  - 1.40 - 1.45mm (0.055 to 0.057 in)
  - 1.50 - 1.55mm (0.059 to 0.061 in)
  - 1.60 - 1.65mm (0.063 to 0.065 in)
  - 1.70 - 1.75mm (0.067 to 0.070 in)
  - 1.80 - 1.85mm (0.071 to 0.073 in)
  - 1.90 - 1.95mm (0.075 to 0.077 in)
  - 2.00 - 2.05mm (0.079 to 0.081 in)
  - 2.10 - 2.15mm (0.083 to 0.085 in)
6. Fit shim selected, fit hub aligner; fit socket head cap screws and tighten to 85 Nm (63 lbf.ft).
  7. Fit drive plate assembly and butress ring ensuring that reference marks are aligned or that paint mark on replacement drive plate is facing towards torque converter.
  8. Fit bolts and tighten to 45 Nm (33 lbf.ft).

**Drive plate and ring gear assembly - refit - From engine nos. 42D00594A, 46D00451A and all engines having serial no. prefixes 47D to 51D**

---



**NOTE:** It is not necessary to check setting height on drive plates fitted to engines from the above numbers.

1. Fit hub aligner, fit socket head cap screws and tighten to 85 Nm (63 lbf.ft).
2. Fit ring gear assembly, spacer, drive plate and butress ring ensuring that reference marks are aligned.



**CAUTION:** If a new drive plate is being fitted, paint mark must face towards torque converter, ensure holes in plate are aligned with clearance holes in ring gear.

3. Fit bolts and tighten to 45 Nm (33 lbf.ft).



---

**CRANKSHAFT, MAIN AND BIG-END BEARINGS**

---

**Big-end bearings - remove**

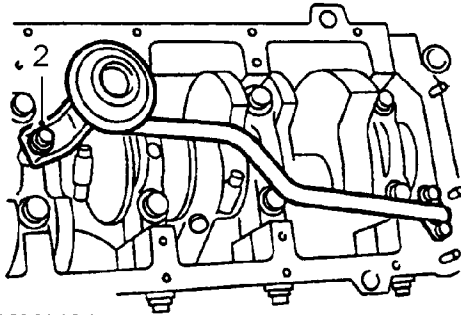

---

1. Remove sump.

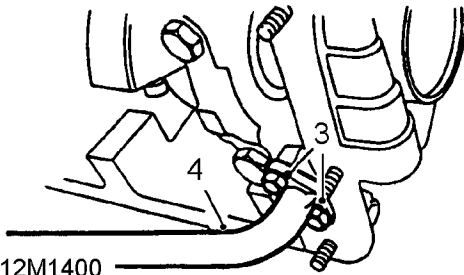

12M1404

2. Remove nut and washers securing oil pick-up pipe to stud.



12M1400

3. Remove 2 bolts securing oil pick-up pipe to oil pump cover, withdraw pipe from cover; remove and discard 'O' ring.
4. Remove oil pick-up pipe, recover spacer from stud.
5. Suitably identify bearing caps to their respective connecting rods.

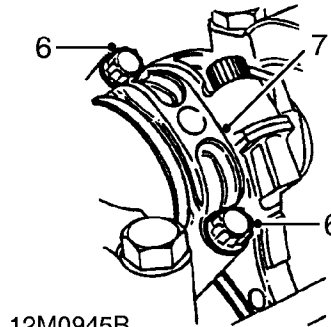

12M0945B

6. Remove 2 bolts securing each bearing cap.
7. Remove bearing cap and bearing shell.



**NOTE:** Keep bearing caps and bolts in their fitted order.

8. Push each piston up its respective bore and remove shells from connecting rods.



**NOTE:** Big-end bearing shells must be replaced whenever they are removed.

# ENGINE

## Big-end bearings - refit

1. Fit bearing shells to each connecting rod.



**NOTE:** Big-end bearings are available in 0.254 mm (0.01 in) and 0.508 mm (0.02 in) oversizes.

2. Lubricate bearing shells and crankshaft journals with engine oil.
3. Pull connecting rods on to crankshaft journals.
4. Fit bearing shells to each big-end bearing cap.



**NOTE:** If crankshaft has been reground, ensure appropriate oversize bearing shells are fitted.

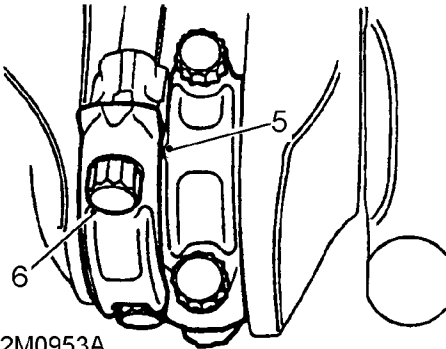

5. Lubricate bearing shells and fit bearing caps ensuring reference marks on connecting rods and bearing caps are aligned.



**NOTE:** Rib on edge of bearing cap must face towards front of engine on RH bank of cylinders and towards rear on LH bank of cylinders.

6. Fit bearing cap bolts and tighten to 20 Nm (15 lbf.ft) then a further 80 degrees.
7. Check connecting rods move freely sideways on crankshaft. Tightness indicates insufficient bearing clearance or misaligned connecting rod.

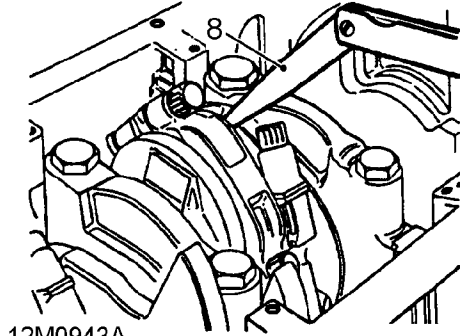

8. Check clearance between connecting rods on each crankshaft journal.  
Connecting rod clearance = 0.15 to 0.36 mm (0.006 to 0.014 in).
9. Clean oil strainer and oil pick-up pipe.
10. Smear a new 'O' ring with engine oil and fit to oil pick-up pipe.
11. Position oil pick-up pipe spacer on number 4 main bearing cap stud.
12. Fit oil pick-up pipe ensuring that end of pipe is correctly inserted in oil pump body.
13. Fit oil pick-up pipe to oil pump body bolts and tighten to 8 Nm (6 lbf.ft).
14. Fit washers and nut securing oil pick-up pipe to stud; tighten nut to 24 Nm (18 lbf.ft).
15. Fit sump.



### Crankshaft - remove

1. Remove flywheel or drive plate and ring gear assembly.
2. Remove timing cover.
3. Remove timing gears.
4. Remove big-end bearings.

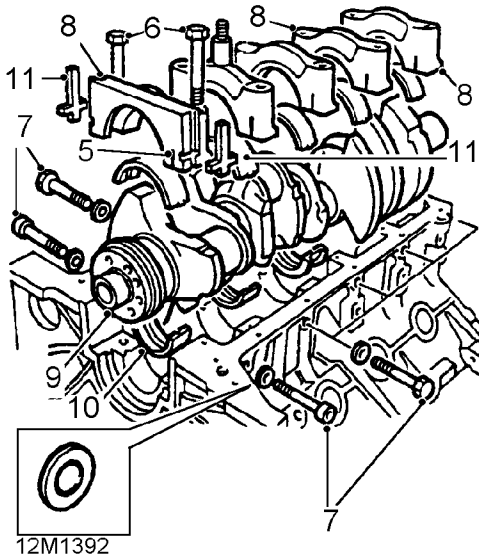

5. Make suitable reference marks between each main bearing cap and cylinder block.
6. Starting at centre main bearing and working outwards, progressively slacken then remove 10 main bearing cap bolts.



**CAUTION: Keep bolts in their fitted order.**

7. Starting at centre main bearing and working outwards, progressively slacken then remove 5 LH side hexagonal head bolts and 4 RH side hexagonal head bolts and one socket head cap bolt; remove and discard Dowty washers.
8. Remove 5 main bearing caps, remove and discard bearing shells.



**NOTE:** Number 4 main bearing cap is drilled to accommodate oil pick-up pipe stud.

9. Lift out crankshaft; remove and discard rear oil seal.
10. Remove and discard 5 bearing shells from cylinder block.



**CAUTION: Main bearing shells must be replaced whenever they are removed.**

11. Remove and discard side seals from rear main bearing cap.
12. Remove all traces of sealant from bearing cap and cylinder block.
13. Remove Woodruff key from crankshaft.

# ENGINE

---

## Knock sensor - remove

---

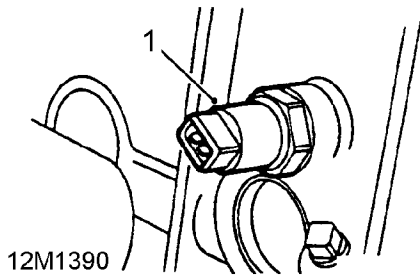

1. Remove knock sensor from cylinder block.

## Crankshaft position sensor - remove

---

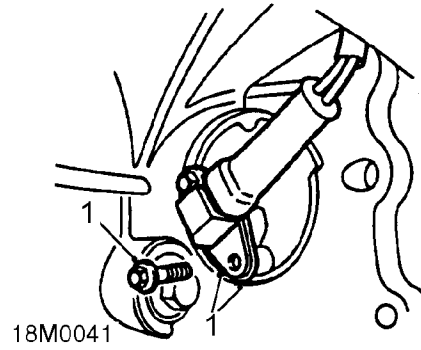

1. Remove 2 bolts securing crankshaft position sensor to gearbox adaptor plate, remove sensor; collect spacer - if fitted.





## Crankshaft - inspection

1. Clean crankshaft and blow out oil passages.

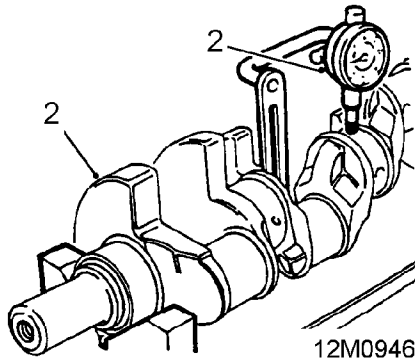

2. Support crankshaft front and rear bearing journals on vee blocks, and using a DTI, measure run-out on centre main bearing. Maximum permitted run-out = 0.08 mm (0.003 in).  
If run-out exceeds permitted maximum, crankshaft is unsuitable for regrinding and should be replaced.

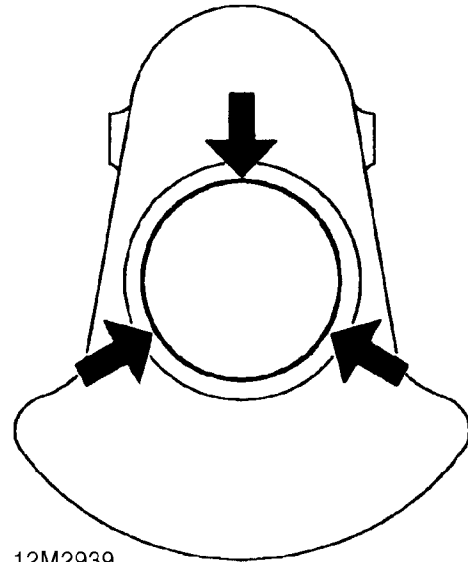

3. Measure each journal for overall wear and ovality, take 3 measurements at 120° intervals at each end and centre of journals.  
Main bearing journal diameter = 63.487 to 63.500 mm (2.499 to 2.52 in)  
Maximum out of round = 0.040 mm (0.002 in).  
Big-end bearing journal diameter = 55.500 to 55.513 mm (2.20 to 2.22 in)  
Maximum out of round = 0.040 mm (0.002 in).  
If measurements exceed permitted maximum, regrind or fit new crankshaft.



**NOTE:** Ovality checks should be made at 120° intervals around each journal.  
Crankshaft main and big-end bearings are available in 0.254 mm (0.01 in) and 0.508 mm (0.02 in) oversizes.

# ENGINE

## Crankshaft dimensions:

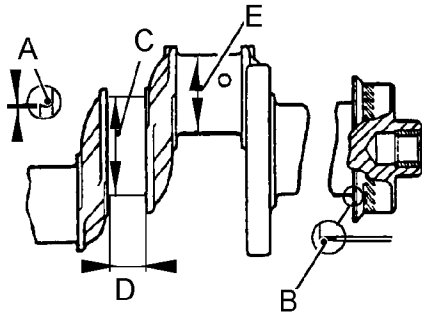

12M0947

Bearing journal radius - all journals except rear main journal **A** = 1.90 to 2.28 mm (0.075 to 0.09 in).  
Rear main bearing journal radius **B** = 3.04 mm (0.12 in).

Bearing journal diameter **C**:  
Standard = 63.487 to 63.500 mm (2.499 to 2.52 in).  
0.254 mm (0.01 in) undersize = 63.233 to 63.246 mm (2.511 to 2.512 in).  
0.508 mm (0.02 in) undersize = 62.979 to 62.992 mm (2.509 to 2.510 in).

Bearing journal width **D**:  
Standard = 26.975 to 27.026 mm (1.061 to 1.064 in).

Bearing journal diameter **E**:  
Standard = 55.500 to 55.513 mm (2.20 to 2.22 in).  
0.254 mm (0.01 in) undersize = 55.246 to 55.259 mm (2.17 to 2.18 in).  
0.508 mm (0.02 in) undersize = 54.992 to 55.005 mm (2.16 to 2.165 in).



**CAUTION:** if crankshaft is to be replaced, ensure replacement is correct for engine being overhauled. Crankshafts are not interchangeable between 4.0 and 4.6 litre engines.

1. Check crankshaft spigot bearing for wear, renew if necessary.

## Crankshaft spigot bearing - renew

1. Carefully extract old spigot bearing.
2. Clean bearing recess in crankshaft.

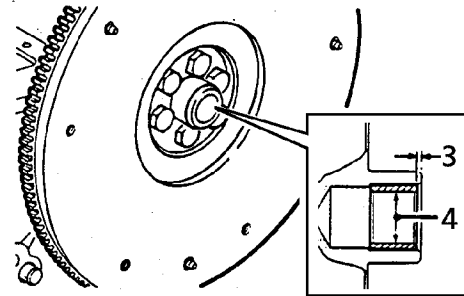

12M0948

3. Fit new bearing flush with, or to a maximum of 1.6 mm (0.06 in) below end face of crankshaft.
4. Ream bearing to correct inside diameter.  
Spigot bearing inside diameter = 19.177 + 0.025 - 0.000 mm (0.75 + 0.001 - 0.000 in).
5. Remove all traces of swarf.



## Crankshaft - refit

1. Clean main bearing caps, bearing shell recesses and mating surfaces of cylinder block.



**CAUTION:** Ensure bolt holes in cylinder block and main bearing caps are clean and dry.

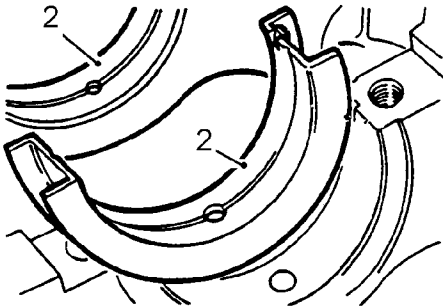

12M0949

2. Fit new upper main bearing shells, with oil holes and grooves, in cylinder block, ensuring flanged shell is fitted in centre position.



**NOTE:** If crankshaft has been reground ensure appropriate oversize bearing shells are fitted.

3. Lubricate main bearing shells with engine oil and position crankshaft in cylinder block.
4. Fit new main bearing shells to bearing caps.
5. Lubricate main bearing shells with engine oil.
6. Fit numbers 1 to 4 main bearing caps ensuring that reference marks made during dismantling are aligned, fit and tighten main bearing cap bolts to 5 Nm (4 lbf.ft).



**NOTE:** Do not fit side bolts at this stage.

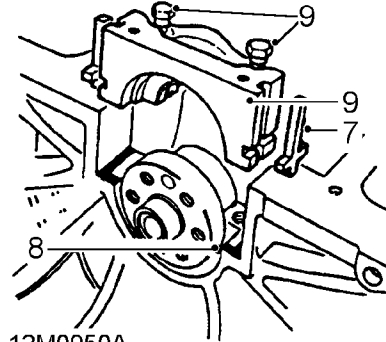

12M0950A

7. Fit side seals to rear main bearing cap.



**CAUTION:** Seals must protrude approximately 1.5 mm (0.05 in) above bearing cap face.

8. Apply a 3 mm (0.12 in) wide bead of Hylomar PL32 jointing compound to bearing cap rear mating face on cylinder block.



**CAUTION:** Ensure sealant does not enter bolt holes.

9. Lubricate rear main bearing shell and side seals with engine oil, carefully fit rear main bearing cap assembly; fit and tighten main bearing cap bolts to 5 Nm (4 lbf.ft).



**CAUTION:** Ensure that engine oil does not enter side bolt holes in bearing cap.

10. Smear new Dowty washers with engine oil and fit to main bearing cap side bolts.
11. Fit and tighten RH then LH side bolts to 5 Nm (4 lbf.ft) ensuring that socket head cap bolt is fitted to rear main bearing cap on RH side of cylinder block adjacent to starter motor aperture.

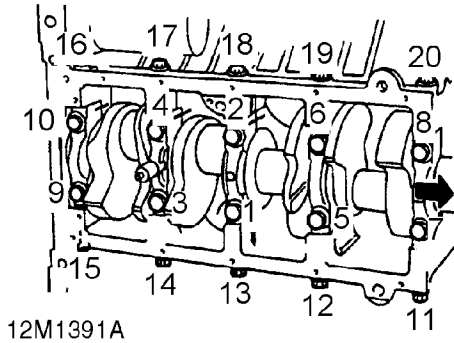

12M1391A

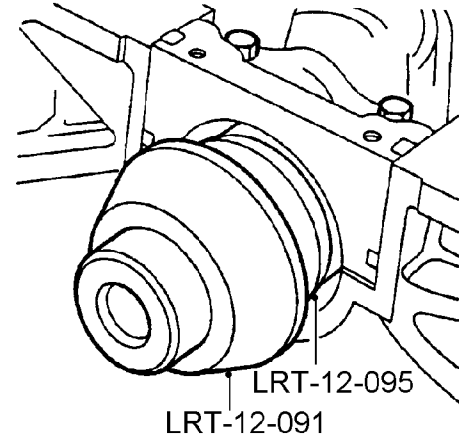

12M1255A

12. Using sequence shown, tighten bolts to:  
 Stage 1 - Initial torque  
 Main bearing cap bolts - 13.5 Nm (10 lbf.ft)  
 Main bearing cap side bolts - 13.5 Nm (10 lbf.ft)  
 Stage 2 - Final torque  
 Main bearing cap bolts numbers 1 to 8 - 72 Nm (53 lbf.ft)  
 Main bearing cap bolts numbers 9 and 10 - 92 Nm (68 lbf.ft)  
 Main bearing cap side bolts 11 to 20 - 45 Nm (33 lbf.ft)
13. Trim off excess material from rear main bearing cap side seals.
14. Clean seal location and running surface on crankshaft.
15. Clean seal protector **LRT-12-095** and lubricate with engine oil.
16. Lubricate oil seal lip with engine oil.

17. Position seal protector **LRT-12-095** to crankshaft.
18. Fit seal using tool **LRT-12-091**.
19. Fit Woodruff key to crankshaft.
20. Check crankshaft end-float.

 **NOTE:** If 0.508 mm (0.02 in) oversize main bearings have been fitted, it may be necessary to machine thrust faces of crankshaft centre main bearing location to achieve correct end-float. Ensure an equal amount of material is removed from each thrust face.

21. Fit big-end bearings.
22. Fit timing cover and gears.
23. Fit flywheel or drive plate and ring gear assembly.
24. Fit sump.



### Crankshaft end - float - check

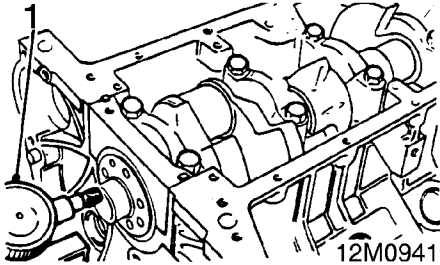

1. Set-up DTI to measure end float.
2. Move crankshaft forwards and zero gauge.
3. Move crankshaft rearwards, record end-float reading obtained.  
Crankshaft end-float = 0.10 to 0.20 mm (0.004 to 0.008 in).
4. Remove DTI.

 **NOTE:** Crankshaft end-float is controlled by thrust faces on upper half of centre main bearing shell. If crankshaft has been reground and 0.508 mm (0.02 in) oversize main bearing shells are to be fitted, it may be necessary to machine thrust faces of crankshaft centre main bearing journal to achieve correct end-float. Ensure an equal amount of material is removed from each thrust face.

### Knock sensor - refit

1. Clean threads of knock sensor and mating threads in cylinder block.
2. Fit knock sensor and tighten to 16 Nm (12 lbf.ft).



**CAUTION:** Do not apply any type of sealant to threads.

## ENGINE

---

### Crankshaft position sensor - refit

---

1. Position crankshaft position sensor and spacer  
- if fitted to gearbox adaptor plate, fit bolts and tighten to 6 Nm (4 lbf.ft).